



**NEXUS ANALYZER**

**User Guide**

Rev 1.5

**Benefits and Applications:**

- System and host port characterization: I2C and low-speed signals.
- 800G capable SI traces
- Ecosystem interoperability testing: I2C sniffer between host and module
- Validates CMIS implementation on module in seconds.
- Voltage noise measurements
- Platform for active modules with module state machine, data path state machine tests and MBM validation tools

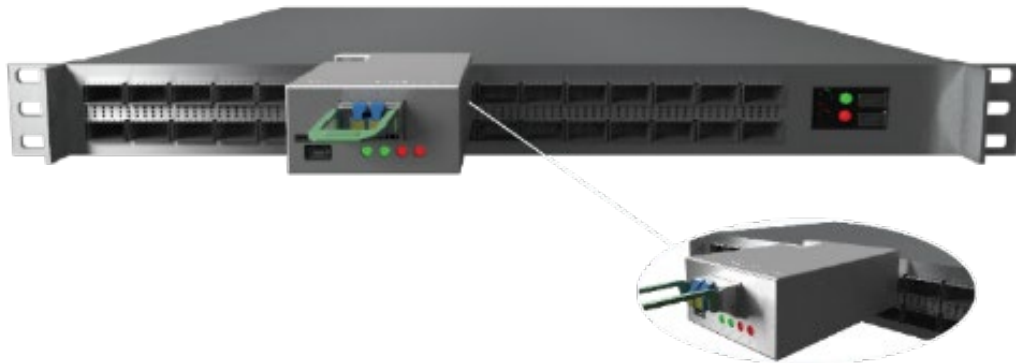

## Table of contents

<b>Key Features</b>	<b>4</b>	I2C Packet Analysis	47
<b>Nexus Hardware</b>	<b>6</b>	Continuous Capture	48
<b>Nexus GUI Installation</b>	<b>7</b>	Single Capture	49
<b>Nexus GUI</b>	<b>9</b>	I2C Trigger Capture	49
<b>Nexus GUI Features</b>	<b>16</b>	I2C Tracking Capture	50
Monitor	16	Packet details expansion	51
Module Controls	18	Scope Mode	52
FEC	18	State Machine Test	54
Common Data Management (CDB)	22	Module Side	55
Control Signals	26	Host Side	58
I2C Read/Write Operations	28	<b>C-CMIS</b>	<b>63</b>
MSA Table	28	Monitor	63
MSA Validation	30	Media Lane:	63
Module side	30	Host Lane	64
Host Side	37	Module Controls	65
Module Emulation	37	Media Lanes	65
Graphs and Measurements	41	Host Lanes	66
VCC Measurements	44	MSA Table	67
Current Measurements	45	MSA Validation	68
In-rush current measurements	46	<b>Revision History</b>	<b>69</b>
		<b>Software and Firmware Revision History</b>	<b>70</b>
		<b>Appendix</b>	<b>71</b>

## Key Features

The same key features below apply for every available form factor of Nexus.

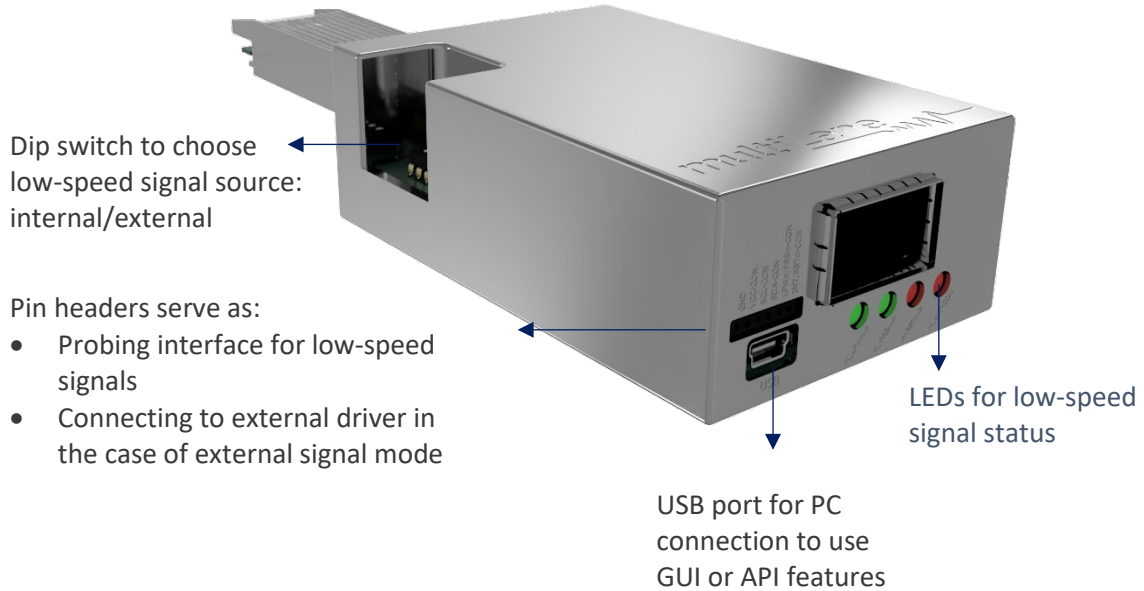

### Adapter

800G Adapter Key Features:

- SI traces and connector support 112G rates
- Support up to 30W modules
- Current and temperature sensor
- Module power ripples and inrush current measurement
- Detection of power spikes during module state transitions
- Probing interface for Vcc and GND pins
- External I2C
- Dip switch to choose low-speed signal source: internal/external

Available in all SFF/CMIS form factors

### Analyzer

800G Analyzer Key Features:

- Voltage sensor
- ePPS signal validation
- 1 MHz I2C
- Probing interface for low-speed signals
- External control for any low-speed signal:
  - INT/RST
  - LPW/PRS
  - SDA
  - SCL
- LEDs for control/alarm signal status
- USB port for PC connection to use GUI or API features

Available in all SFF/CMIS form factors

Measured Insertion Loss data of 800G OSFP Adapter

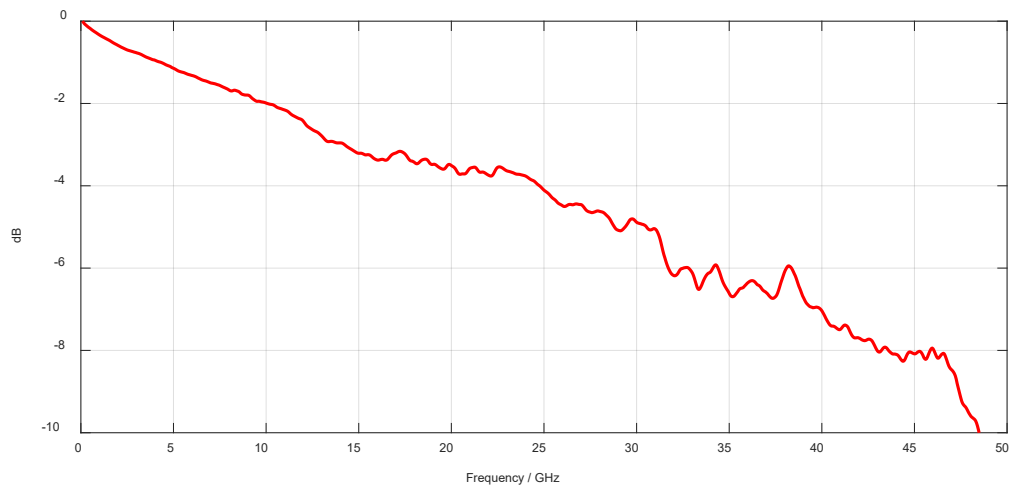

Measured Insertion Loss data of 800G QSFP-DD Adapter:

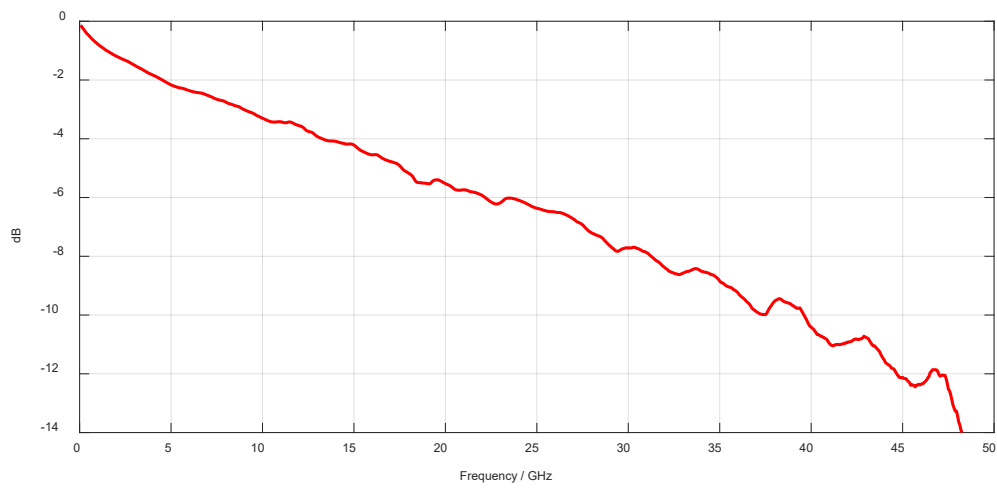

## Nexus Hardware

Nexus includes an adapter with 800G traces, which supports 30W modules. Through a set of low-speed pin headers, the adapter mates with the analyzer which gives the user access to the Nexus Software.

The hardware also includes a dip switch, and a front probing interface for low-speed signals access and control:

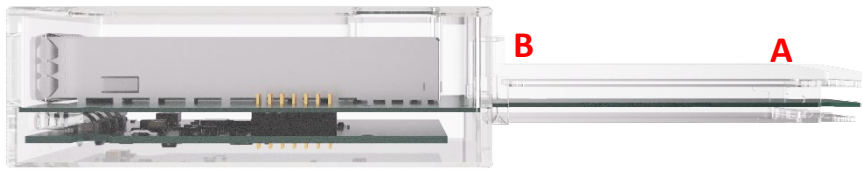

**A:** Signals from host side at plug

**B:** Signals to connector inside Nexus, going to module

Low-speed signals	Dip switch		Front Pin Headers	
	ON	OFF	DIP SWITCH ON	DIP SWITCH OFF
<b>SCL</b>	Plug connected to connector	Front pin headers to connector, plug side disconnected	Probing interface	External driver
<b>SDA</b>	Plug connected to connector	Front pin headers to connector, plug side disconnected	Probing interface	External driver
<b>INT/RSTn</b>	Plug connected to connector	Front pin headers to connector, plug side disconnected	Probing interface	External driver
<b>LPWn/PRSn</b>	Plug connected to connector	Front pin headers to connector, plug side disconnected	Probing interface	External driver

## Dipswitch ON

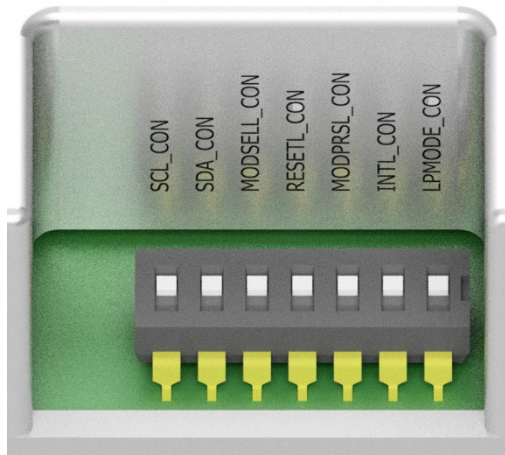

## Dipswitch OFF

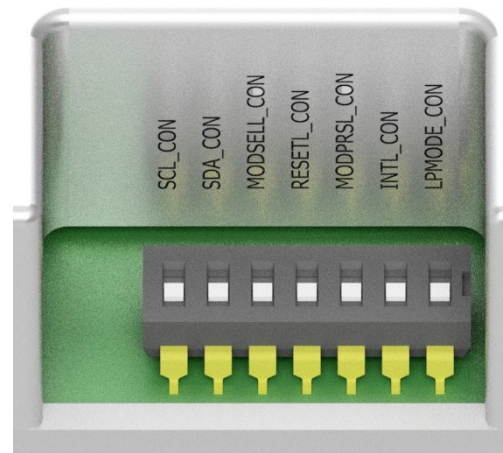

Each low-speed signal can be controlled independently from the next. To switch each of the low-speed signals sources, it suffices to slide its' switch to the top or bottom side

## Nexus GUI Installation

**GUI installation is only accessible to users with ML4066-NX-Pro.** This does not apply and is inaccessible to users with ML4066-NX-HW.

The GUI installation license is available per each single ML4066-NX-Pro unit.

### Step 1: USB Driver

- Download USB Driver
- [https://multilaneinc.com/wp-content/uploads/2023/06/ML4066\\_ANA\\_V2\\_USB\\_Driver\\_Signed\\_V0.1.zip](https://multilaneinc.com/wp-content/uploads/2023/06/ML4066_ANA_V2_USB_Driver_Signed_V0.1.zip)
- Power up Nexus by plugging it into host
- Connect Nexus to the PC through USB cable
- Download the USB driver file
- Go to "Device Manager"
- Find the target device that need to install the driver
- Right-click on the device and select Update Driver Software
- Select Browse my computer for driver software
- Browse you PC and select the driver file
- Click Next and wait until the driver is installed

## Step 2: Download Software

The below button redirects you to the software download which supports every available form factor

DOWNLOAD

## Step 3: Connection & Initialization

Once the software was downloaded, you can access it and the below screen should appear:

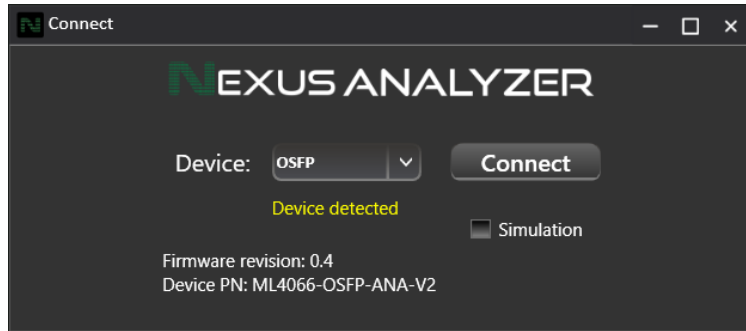

Choose the device form factor accordingly and press "Connect".

Press "Simulation" for a GUI test run without hardware: Simulation mode is also accessed through a simulation license provided by MultiLane.



## Nexus GUI

Upon connection and initialization, below is how the Nexus GUI appears on screen

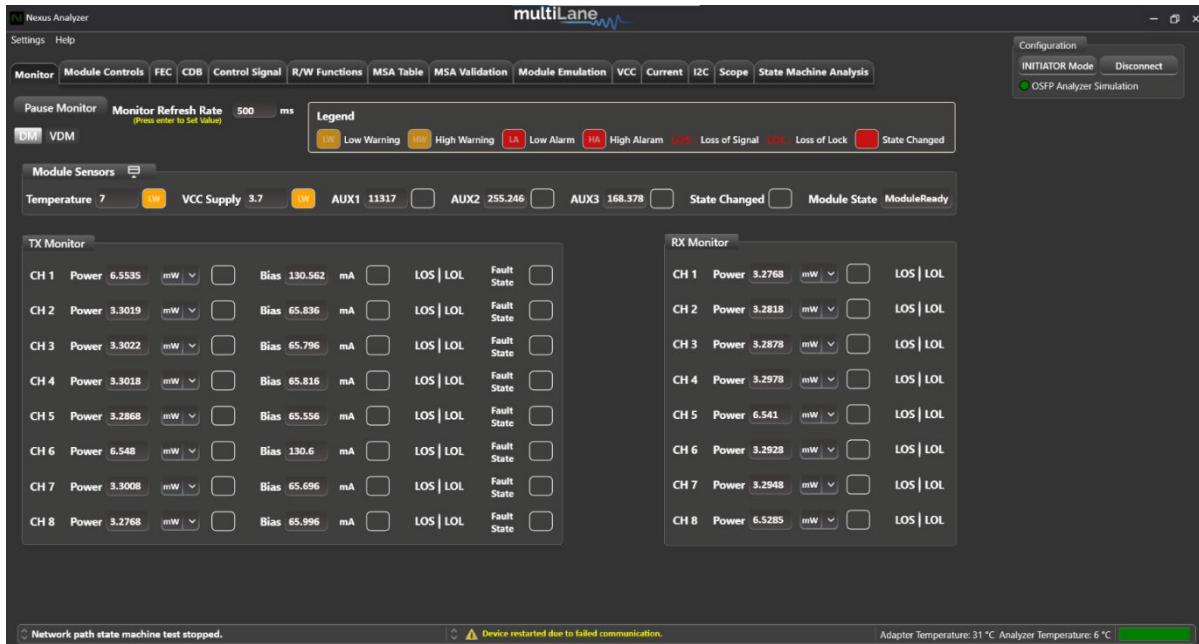

For more information about the Nexus unit, the firmware and software revisions implemented and used, refer to “Settings” and “Help” on the top left corner of the GUI:

Under “Settings” you will find:

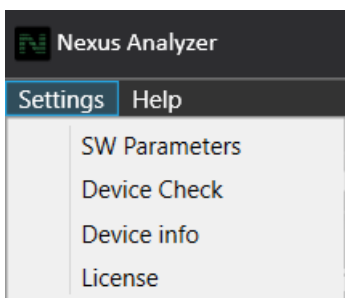

- SW Parameters: This is available to check storage information, log size of files to be exported from Nexus throughout the application and their respective location.
- SW Parameters also allows user to increase the log size of all data to be measured and saved throughout the application, in the following tabs: I2C, VCC, Current and Scope Mode.



- Device Check: press on “Check Device” for a device power up health check. The LEDs on the right side of the window will either turn green, indicating a healthy device, or red, indicating an issue in the power up of Nexus.

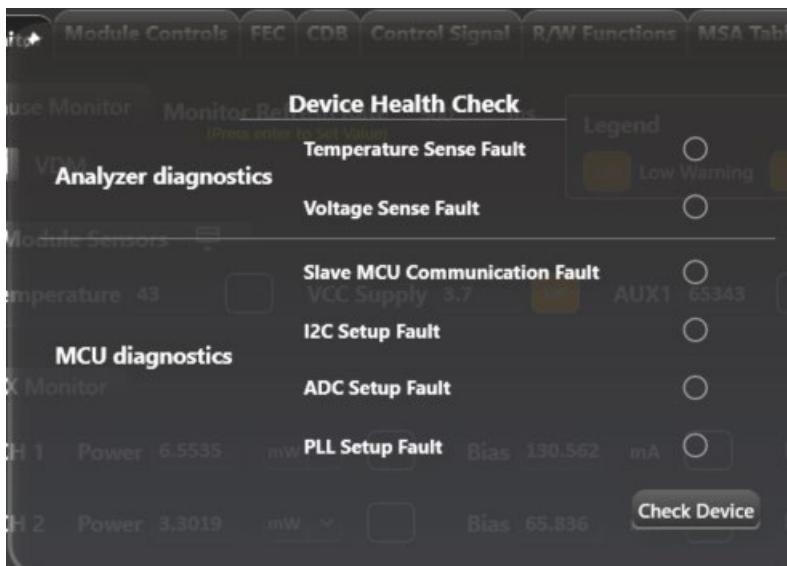

- Device Info: check Nexus Part Number and Firmware Revision, as well as device Serial Number.

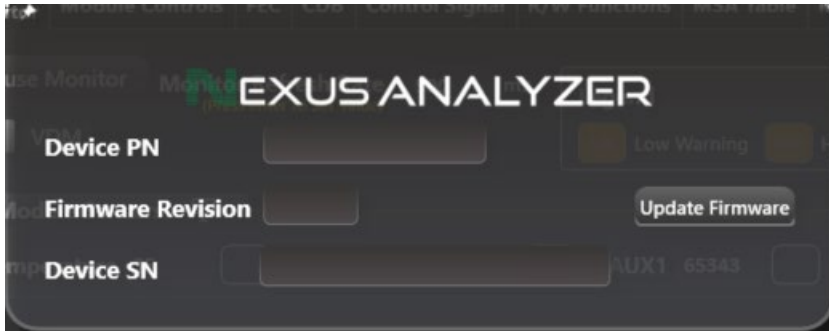

- License: this is useful to users with ML4066-NX-HW who want to upgrade to ML4066-NX-Pro which will require a license. Users with ML4066-NX-Pro will not need a license.

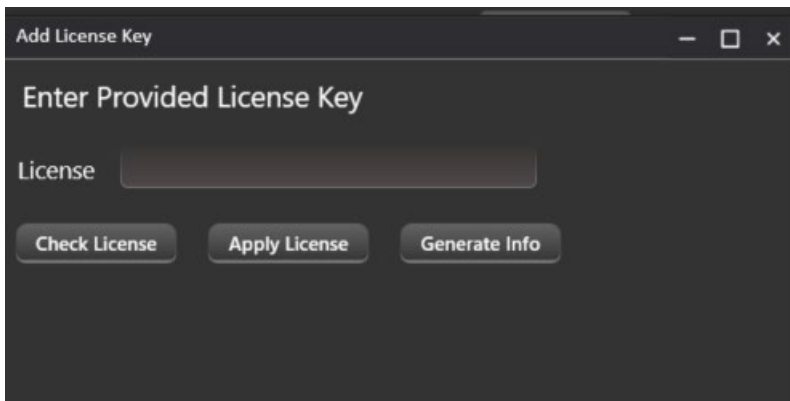

Press **“Help”**, and then **“About us”** for more information on the Software revision being used and accessing software revision history:

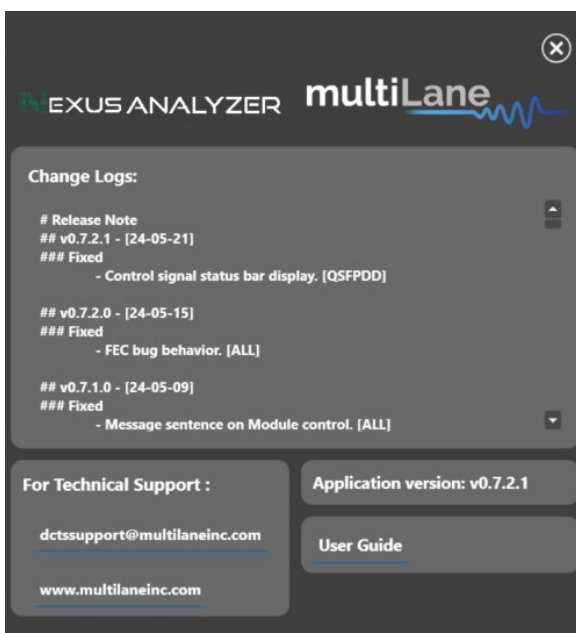

Nexus GUI Features	Description
Monitor	Diagnostic and Versatile Diagnostic Monitoring
Module Controls	Access to TX and RX controls
FEC	Monitor FEC status on their module.
Common Data Block (CDB)	Update their module firmware.
Control Signals	Access to low-speed signals in three different modes
R/W Functions	I2C read/write operations
MSA Table	Gives the user access to their module memory.
MSA Validation	Full CMIS/SFF register sweep.
Module Emulation	Emulation Module Memory to validate the host.
VCC	Continuous VCC Supply measurements.
Current	Continuous and in-rush current measurements.
I2C	I2C packets capturing and packet details analysis.
Scope Mode	SCL, SDA, VCC and Current measurements.
State Machine Analysis Tab	State Machine, Data Path State Machine, and Module State Behavior tests available.

Nexus operates in three modes:

- Target mode: the analyzer acts as a module for a host DUT. Nexus will emulate module memory and behavior, while the user tests host capabilities, including R/W capabilities.
- Initiator mode: the analyzer acts as a host for a module DUT. Nexus will emulate host behavior and access everything on the module inserted including memory, low-speed signals, all parameters advertised, effectively testing module functionality and CMIS implementation.
- Bypass mode: the analyzer monitors exchange between host and module, accessing and testing communication between the two.

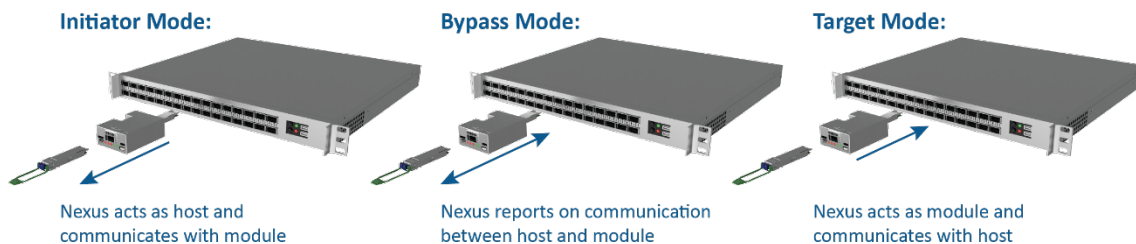

To change the mode of Nexus on the GUI, follow the steps below:

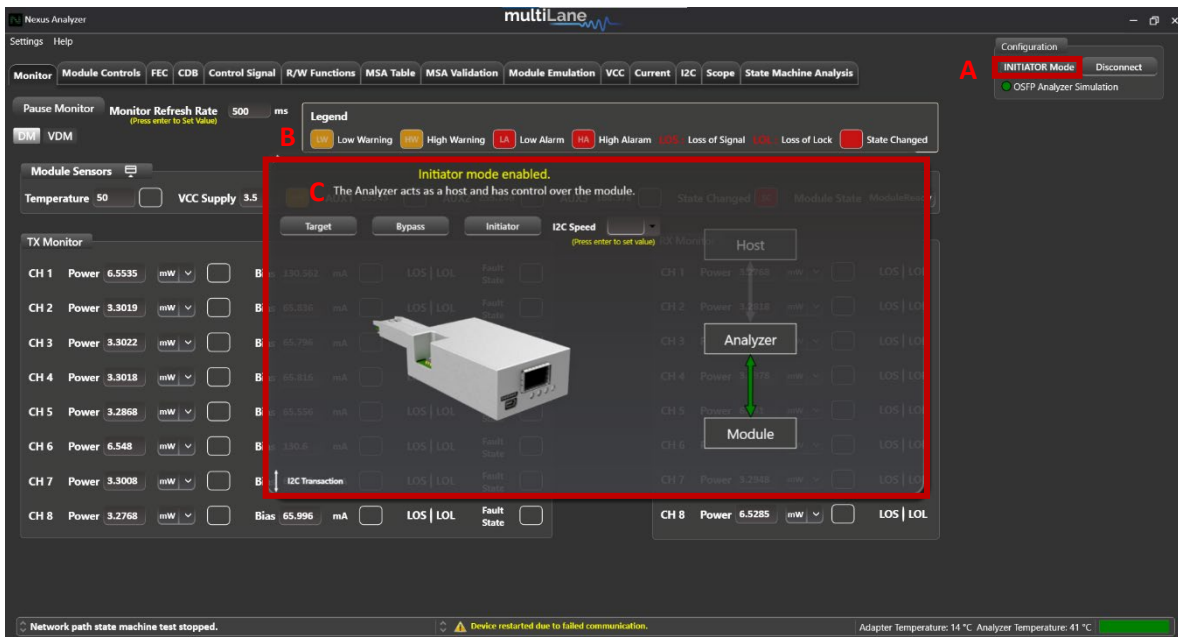

- A: Press on this button to access all three modes
- B: This window will appear after pressing the button from A
- C: Press any desired mode

Setting I2C Speed;

User can set an I2C speed to work through their application by following the steps below:

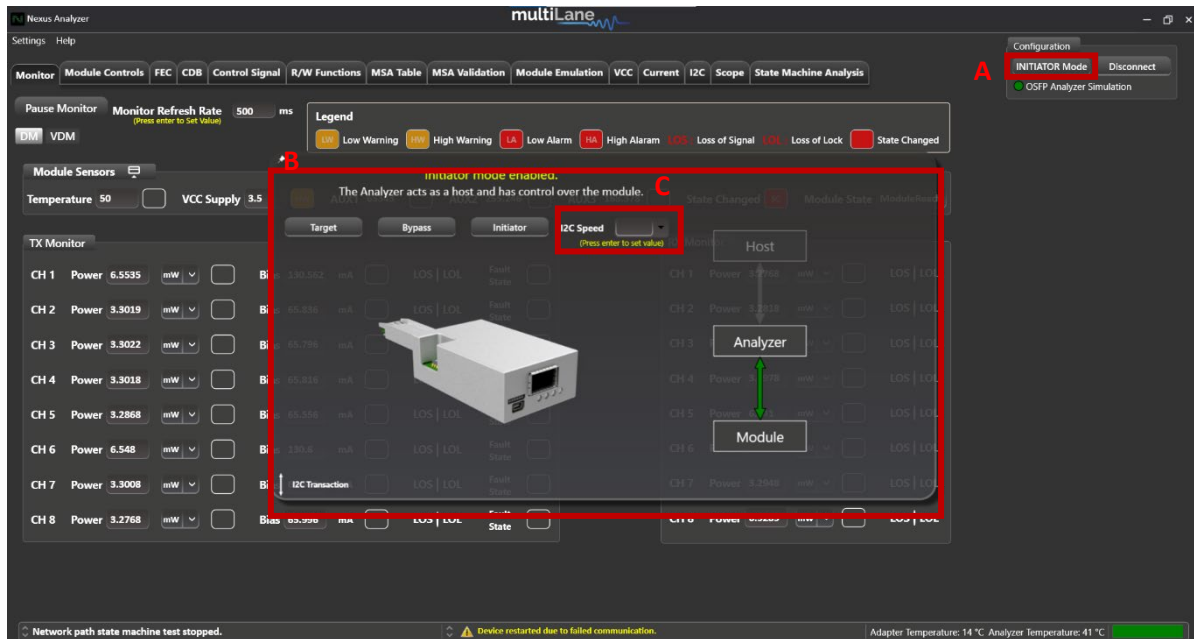

## Set Control Signals Defaults:

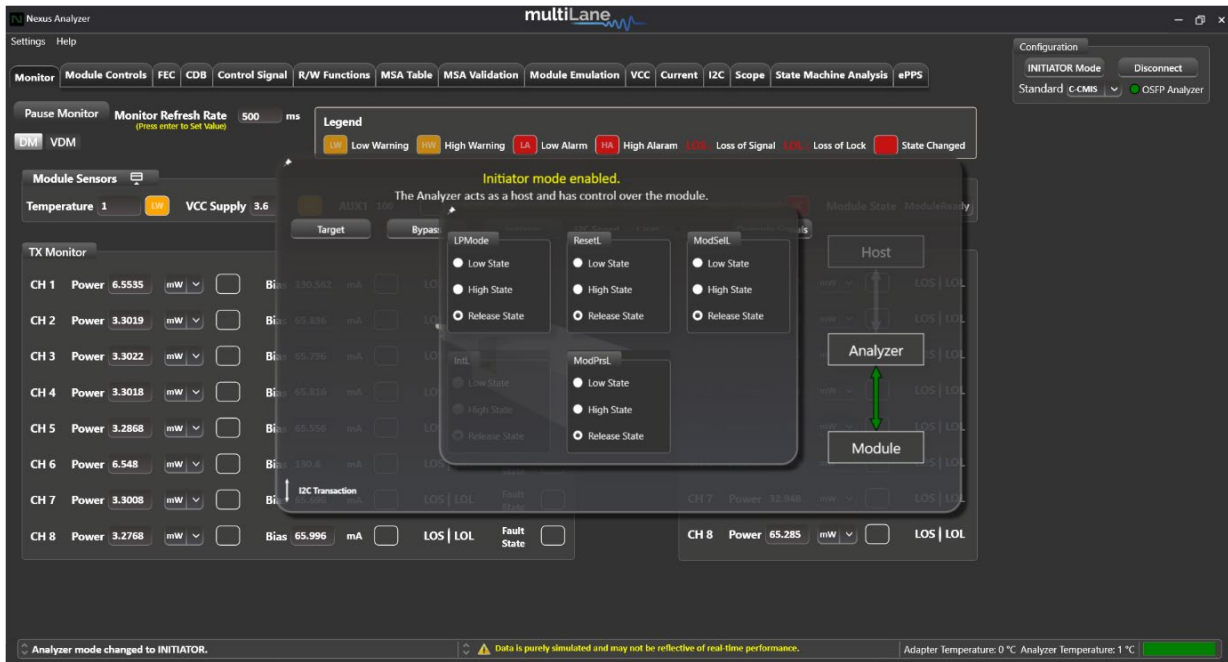

After choosing a mode to enable and work with, user can access low-speed signals on plug/host side to override them. These low-speed signals are accessible at any point in the GUI.

On the bottom left of the UI, there is a status bar for Nexus, and it will be updated throughout user application, effectively resetting when the user disconnects from the GUI, see example below

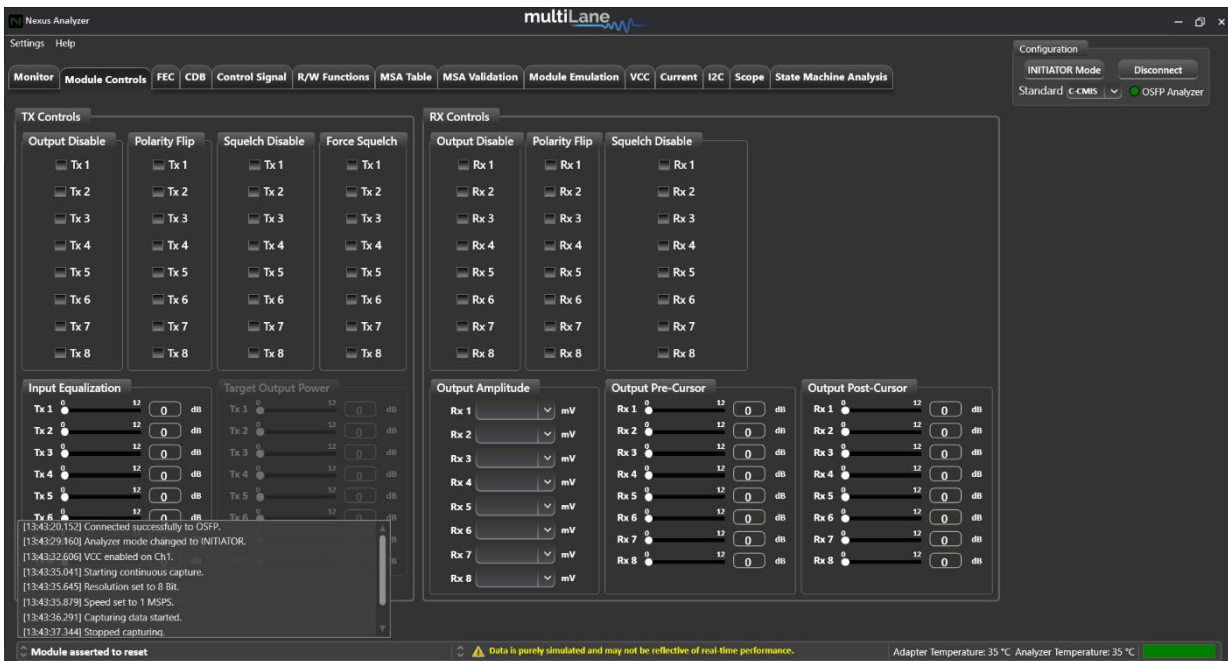

---

## Firmware Upgrade on Nexus:

---

The latest firmware revision on Nexus is v0.5.1.5.

It is possible to update the FW revision directly from user side, following the steps below:

- On the top right of the UI, press on Settings -> Device Info -> Update Firmware
- You will be redirected to FW packages already downloaded with the full Nexus UI setup:
  - OSFP/QDD FW packages will be available
  - Select the corresponding form factor, and select “QDD\_FirmwarePackage.hex” or “OSFP\_FirmwarePackage.hex”
- Update device
- Please reach out to [dctssupport@multilaneinc.com](mailto:dctssupport@multilaneinc.com) for a FW upgrade guide.

The FW Upgrade procedure might require the disabling of anti-virus of the laptop in use. Please refer to your IT department.

In the case that this is not possible, try using a laptop that is not limited to your company firewall restrictions

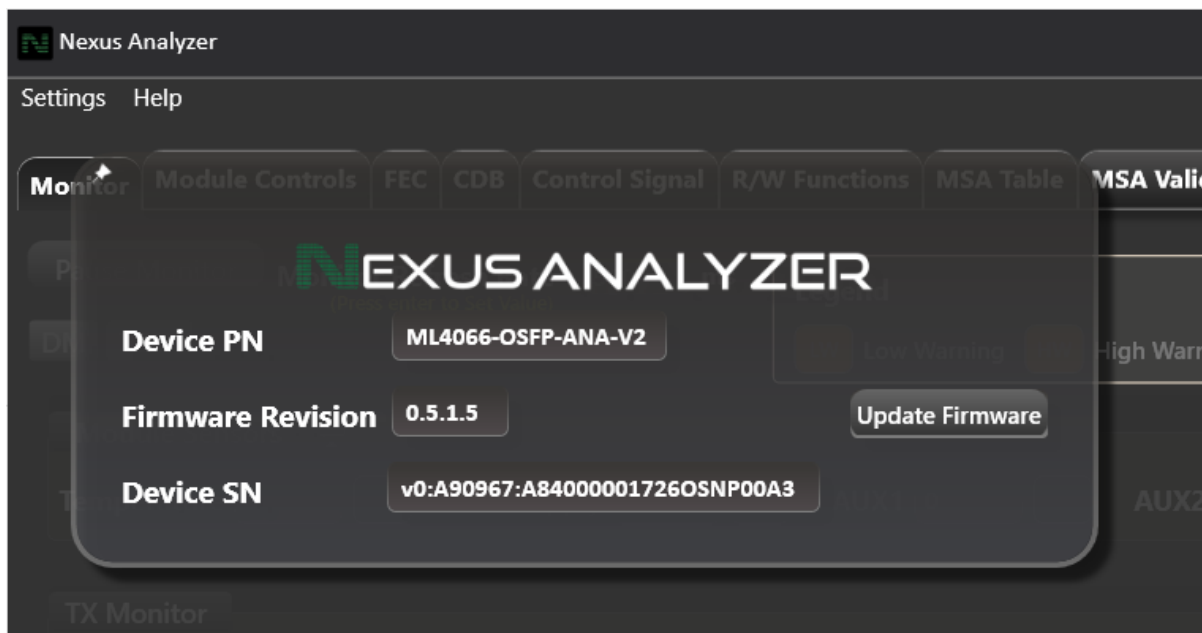

Additionally, please be in touch with our team as we can ship the unit to the nearest location and upgrade the FW from our side



## Nexus GUI Features

### Monitor

#### Digital Monitoring

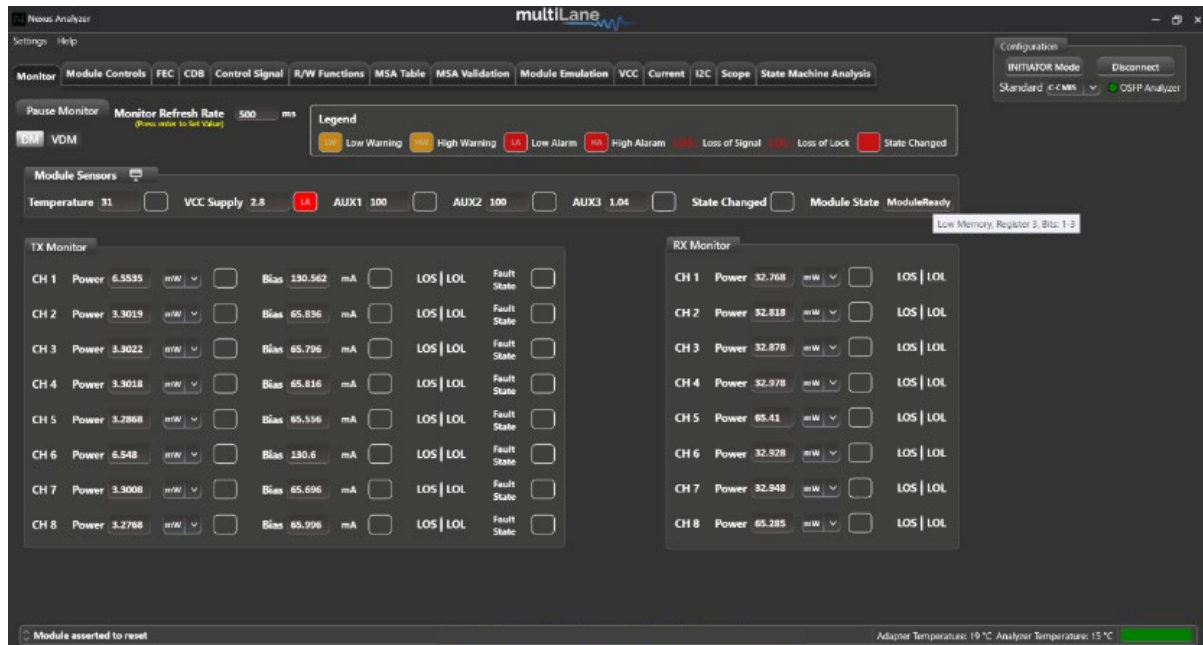

- Operates in initiator mode
- Module monitoring interface
- Color coded high alarms/ high warnings.
- Color coded low alarms/ low warnings.

Module Sensors can be docked to the top of the GUI by pressing on the docking icon, right side of “Module Sensors”



## Versatile Diagnostic Monitoring

The screenshot displays the Nexus Analyzer software interface. At the top, there are tabs for 'Settings' and 'Help'. Below that, a 'Monitoring' section shows 'Adapter Temperature' at 38 and 'Analyzer Temperature' at 49. A 'Configuration' panel on the right indicates 'OSIP Analyzer' is active in 'INITIATOR Mode' with a 'Disconnect' button.

The main interface features a menu bar with options: Monitor, FEC, CDB, Control Signals, R/W Functions, MSA Table, MSA Validation, Module Emulation, VCC, Current, I2C, Scope, State Machine Analysis, and ePPS. Below the menu, there are controls for 'Pause Monitor', 'Monitor Refres' (500 ms), and 'DM' (VDM). A 'Legend' section defines status indicators: Low Warning (yellow), High Warning (orange), Low Alarm (red), High Alarm (red), Loss of Signal (red), Loss of Lock (red), and State Changed (red).

The primary data area is a table with columns for 'Descriptor/Samples' and 'Mask Flag And Threshold'. The table lists 64 samples, each with a numerical descriptor and a 'Descriptor' field set to 0. The samples are arranged in four columns of 16 rows each.

Sample	Descriptor	Mask Flag	Threshold
Sample 1	6425	0	0
Sample 2	29298	0	0
Sample 3	29555	0	0
Sample 4	24929	0	0
Sample 5	20046	0	0
Sample 6	29812	0	0
Sample 7	28527	0	0
Sample 8	27499	0	0
Sample 9	8224	0	0
Sample 10	7196	0	0
Sample 11	20301	0	0
Sample 12	17990	0	0
Sample 13	11965	0	0
Sample 14	12386	0	0
Sample 15	18247	0	0
Sample 16	17476	0	0
Sample 17	13864	0	0
Sample 18	8224	0	0
Sample 19	13864	0	0
Sample 20	22616	0	0
Sample 21	21508	0	0
Sample 22	22886	0	0
Sample 23	22593	0	0
Sample 24	22586	0	0
Sample 25	14135	0	0
Sample 26	8224	0	0
Sample 27	8224	0	0
Sample 28	22850	0	0
Sample 29	22316	0	0
Sample 30	22593	0	0
Sample 31	8224	0	0
Sample 32	8224	0	0
Sample 33	8224	0	0
Sample 34	8224	0	0
Sample 35	8224	0	0
Sample 36	8224	0	0
Sample 37	22896	0	0
Sample 38	0	0	0
Sample 39	0	0	0
Sample 40	0	0	0
Sample 41	0	0	0
Sample 42	61680	0	0
Sample 43	1542	0	0
Sample 44	0	0	0
Sample 45	0	0	0
Sample 46	0	0	0
Sample 47	0	0	0
Sample 48	22316	0	0
Sample 49	0	0	0
Sample 50	0	0	0
Sample 51	0	0	0
Sample 52	0	0	0
Sample 53	0	0	0
Sample 54	0	0	0
Sample 55	0	0	0
Sample 56	0	0	0
Sample 57	0	0	0
Sample 58	0	0	0
Sample 59	0	0	0
Sample 60	0	0	0
Sample 61	0	0	0
Sample 62	0	0	0
Sample 63	59624	0	0
Sample 64	2270	0	0

- Operates in initiator mode
- Access to enabled/disabled groups in the module
- Indexing available for module interrupts

## Module Controls

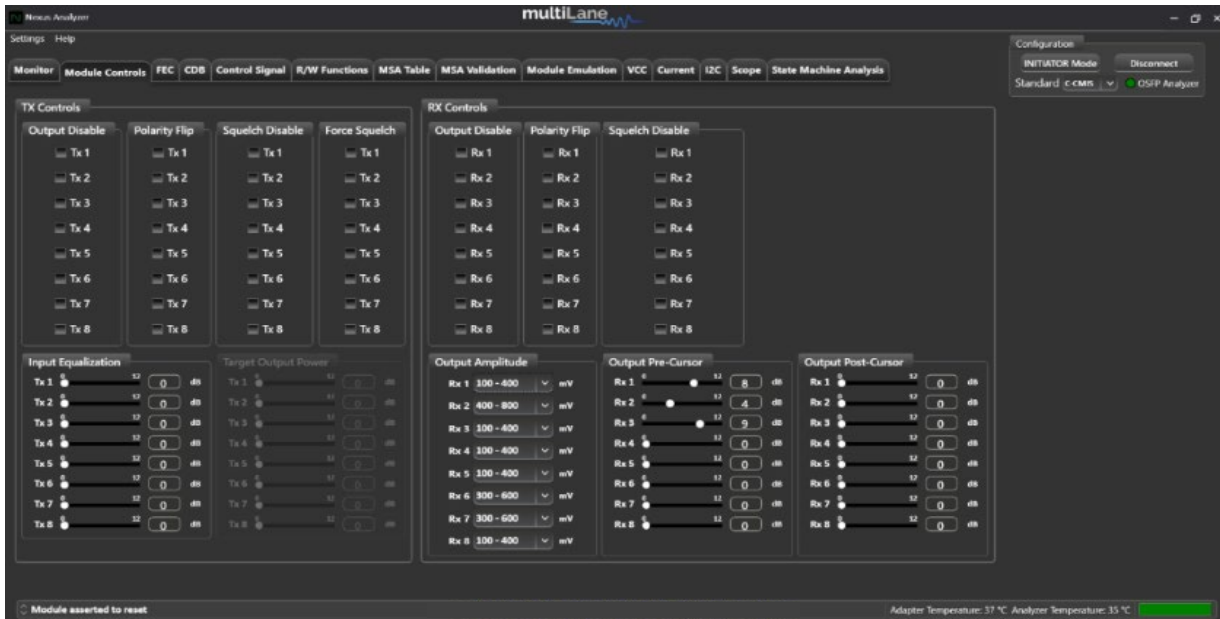

- Initiator Mode
- Gives user access to TX and RX controls
  - Output disable
  - Polarity flip
  - Squelch disable
  - Force squelch
- Control and monitoring over TX equalization techniques.

## FEC

The FEC Tab includes FEC Advertisement, FEC Configuration and BER/FEC Monitor.

As soon as user hovers their mouse on the FEC tab in either window, a tooltip will appear to indicate each register read from for each corresponding parameter.

In FEC Advertisement, Nexus will read register 130 from page 13h to determine whether the module used supports Host and Media side FEC. In case of no FEC support, this tab will cease to function. Otherwise, Nexus will proceed to read the set of registers 128, 131, 132, 133, 134, 135, 136, 137, 138, 139, 141, 142, from page 13h. From the data read, Nexus will monitor the correct parameters in Host and Media side FEC.

## FEC Advertisement

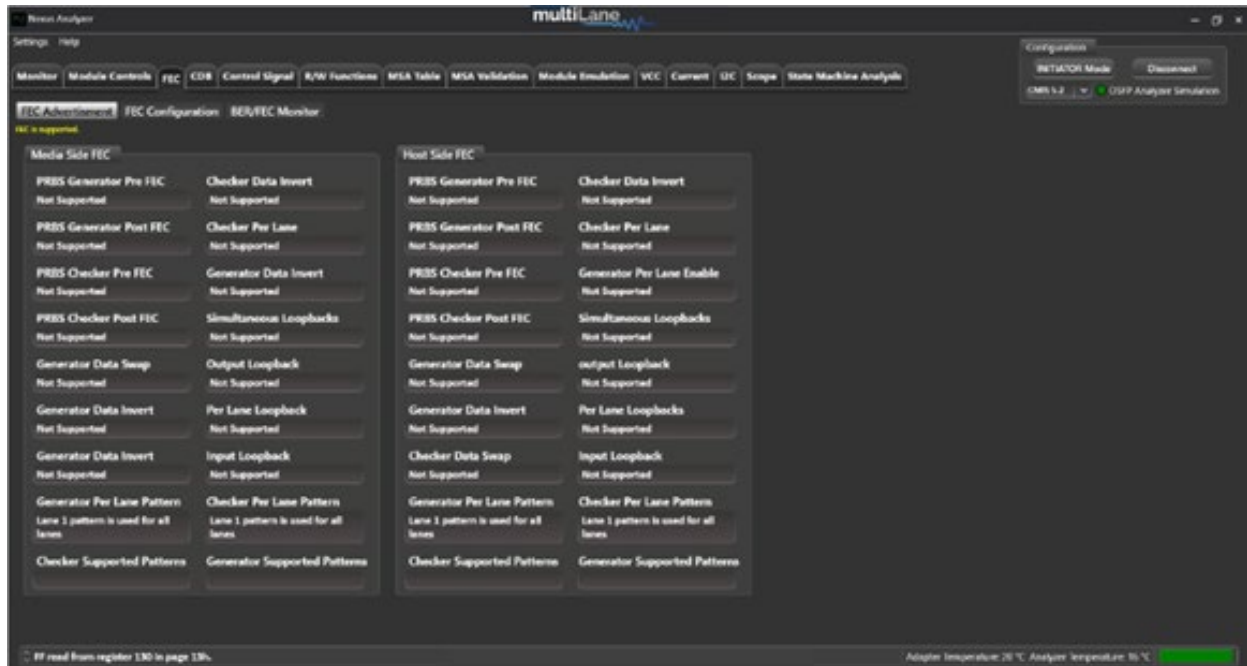

- Operates in initiator mode
- FEC advertisement for transceiver characteristics
- Access to post FEC
- FEC Monitoring interface for BER, error count, and SNR

Reads FEC diagnostics from module, implements MSA formatting and presents final BER data

## FEC Configuration

FEC Configuration feature allows the user to correctly configure module parameters before monitoring BER/FEC. Parameters include Host and Media PRBS generator and checker clocks, as well as host and media side parameters for each of the channels as shown below.

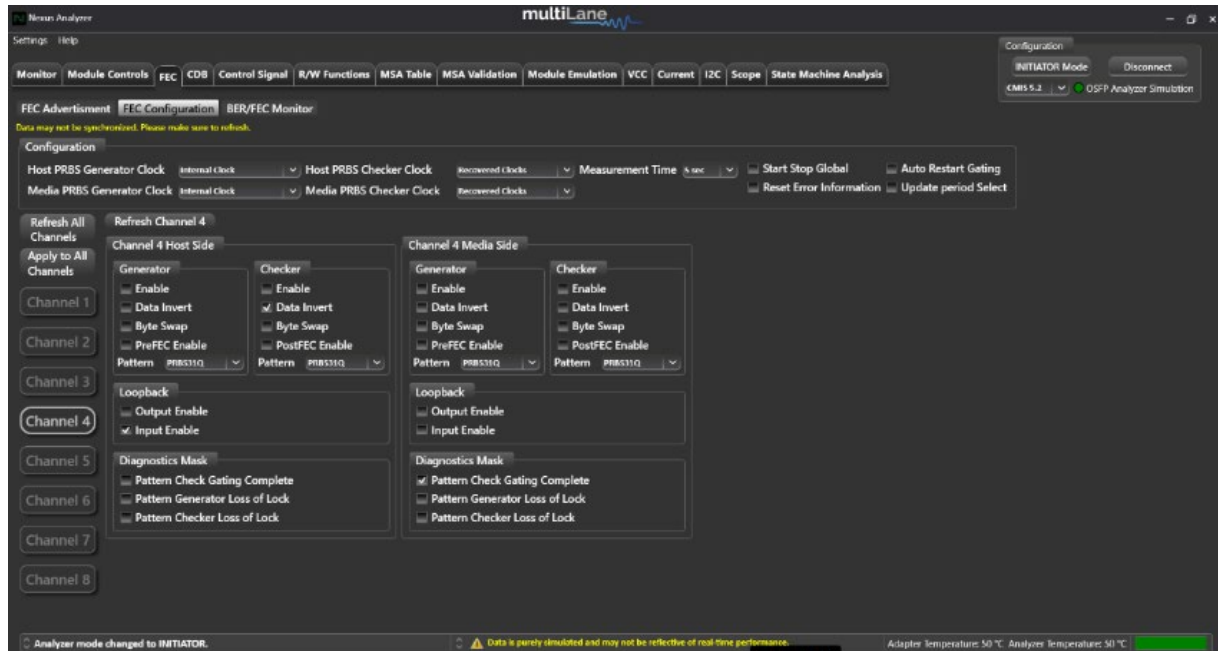

- Allows user to configure module
- Operates in Initiator mode
- Allows user to set PRBS generator clock on host and media side

Allows user to configure each channel by itself including generator and checker, loopback, and diagnostics mask on host and media side

## FEC Monitor

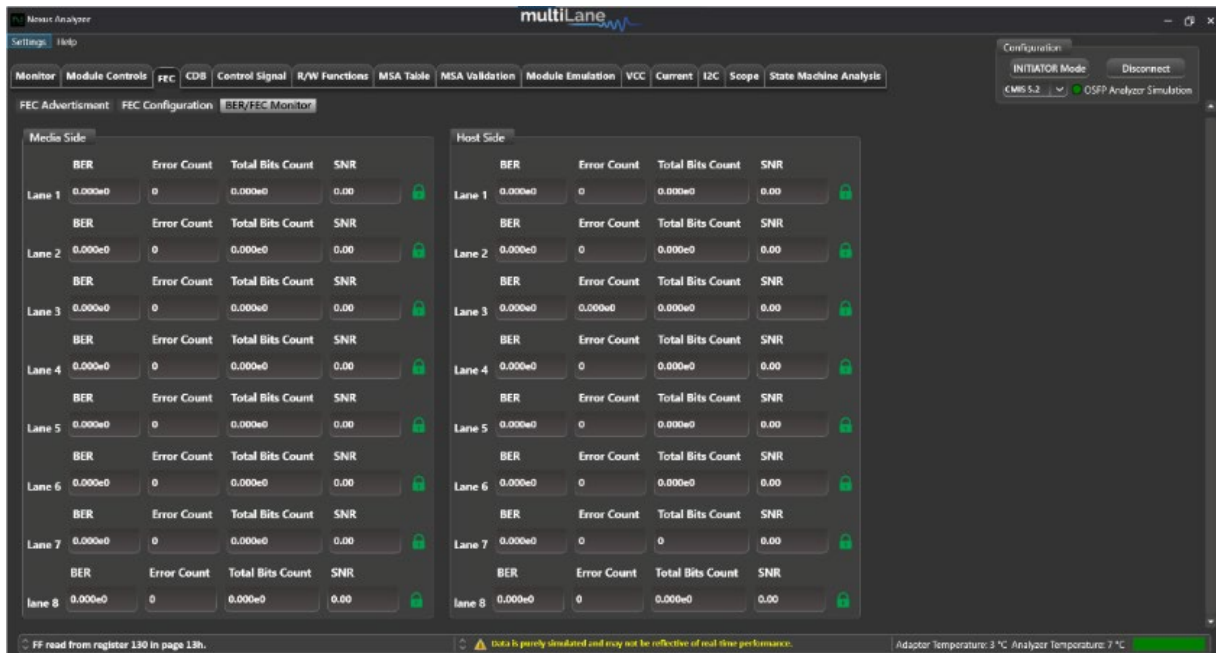

- Operates in initiator mode
- FEC Monitoring interface for BER, error count, and SNR

Reads FEC diagnostics from module, implements MSA formatting and presents final BER data

#### Media Side:

- BER: Page 14h, registers 208 through 223. The values read are then calculated through F16 equation as per CMIS5.2, section 3.4.
- Error count: page 14h
  - Lanes 1 and 5: registers 192 through 199
  - Lanes 2 and 6: registers 208 through 215
  - Lanes 3 and 7: registers 224 through 231
  - Lanes 4 and 8: registers 240 through 247
- Total Bits Count: page 14h
  - Lanes 1 and 5: registers 200 through 207
  - Lanes 2 and 6: registers 216 through 223
  - Lanes 3 and 7: registers 232 through 239
  - Lanes 4 and 8: registers 248 through 255
- SNR: page 14h, registers 240 through 256. The values read are then divided by 256 as per CMIS5.2, section 8.13.3

**Host side:**

- BER: Page 14h, registers 192 through 207. The values read are then calculated through F16 equation as per CMIS5.2, section 3.4.
- Error count: page 14h
  - Lanes 1 and 5: registers 192 through 199
  - Lanes 2 and 6: registers 208 through 215
  - Lanes 3 and 7: registers 224 through 231
  - Lanes 4 and 8: registers 240 through 247
- Total Bits Count: page 14h
  - Lanes 1 and 5: registers 200 through 207
  - Lanes 2 and 6: registers 216 through 223
  - Lanes 3 and 7: registers 232 through 239
  - Lanes 4 and 8: registers 248 through 255
- SNR: page 14h, registers 208 through 223. The values read are then divided by 256 as per CMIS5.2, section 8.13.3

**Common Data Management (CDB)**

CDB operates in initiator mode

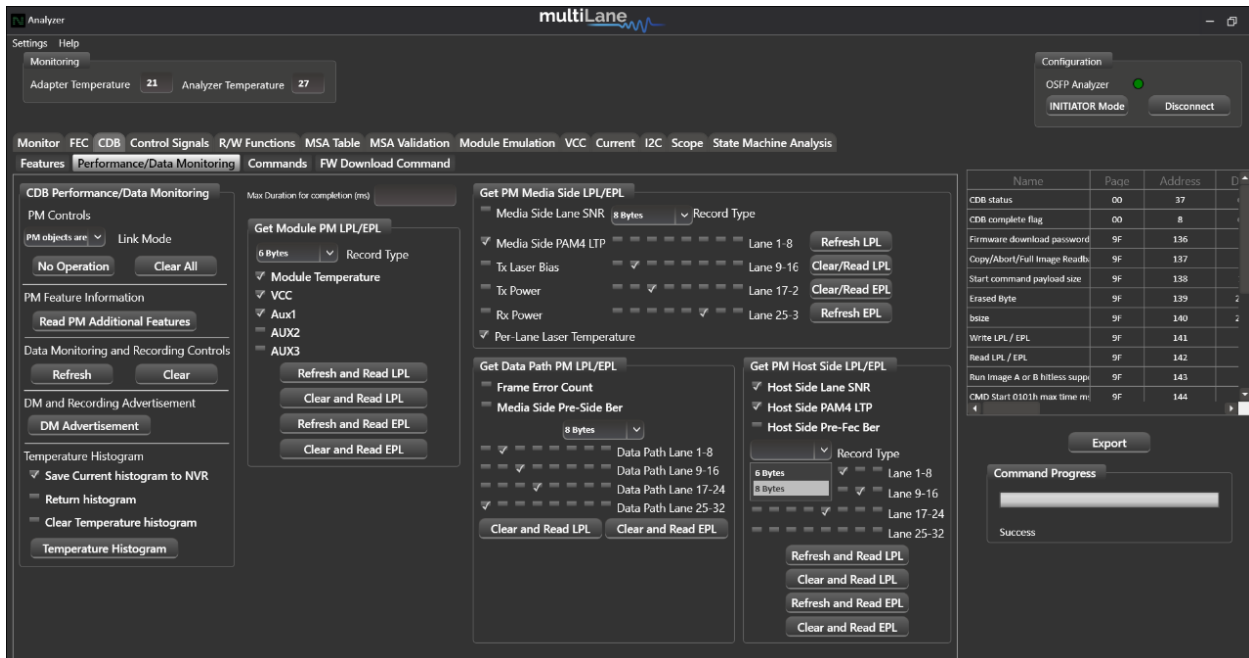

## Performance and Data Monitoring

- CMD 0200h PM Controls: Extract Performance Monitoring data records such as minimum/average/maximum values. “No Operation” reads the most recent values, while “Clear All” clears the extracted values for all lanes in the interconnect.
- CMD 0201h PM Feature Information: Reads the PM’s additional features.
- CMD 0280h Data Monitoring and Recording Controls: “Refresh” loads the most recent attributes. “Clear All” clears all values for all parameters for all lanes at the same time.
- CMD 0281h Data monitoring and recording advertisement
- CMD 0290h Temperature Histogram: Displays the temperature intervals of the interconnect and how long it stayed at each temperature interval.
- CMD 0210h, 0211h Get Module PM LPL/EPL: Choose parameters of the module’s performance monitoring records, and replace the current values of the minimum, average, and maximum values. “Refresh” replaces the old values, while “Clear and Read” reads and resets the old values.
- CMD 0212h, 0213h Get PM Host Side LPL/EPL: Choose parameters of the host’s performance monitoring records, and replace the current values of the minimum, average, and maximum values. “Refresh” replaces the old values, while “Clear and Read” reads and resets the old values.
- CMD 0214h, 0214h Get PM Media Side LPL/EPL: Choose parameters the performance monitoring records of specific lanes, and replace the current values of the minimum, average, and maximum values. “Refresh” replaces the old values, while “Clear and Read” reads and resets the old values.
- CMD 0216h, 0217h Get Data Path PM LPL/EPL: Choose the data path for specific lanes and replace the current values of the minimum, average, and maximum values. “Refresh” replaces the old values, while “Clear and Read” reads and resets the old values.

The screenshot displays the multiLane Analyzer software interface. The main window is titled "Analyzer" and features a top navigation bar with tabs for "Settings", "Help", "Monitoring", "Monitor", "FEC", "CDB", "Control Signals", "R/W Functions", "MSA Table", "MSA Validation", "Module Emulation", "VCC", "Current", "I2C", "Scope", and "State Machine Analysis". The "Performance/Data Monitoring" tab is active, showing various control panels for different PM (Performance Monitoring) commands.

On the left, there are sections for "CDB Performance/Data Monitoring", "PM Controls", "PM Feature Information", "Data Monitoring and Recording Controls", "DM and Recording Advertisement", and "Temperature Histogram". The "PM Controls" section includes buttons for "No Operation" and "Clear All".

The central area contains several configuration panels:

- Get Module PM LPL/EPL:** Includes a "Max Duration for completion (ms)" field, a "Record Type" dropdown, and checkboxes for "Module Temperature", "VCC", "AUX1", and "AUX3". Buttons for "Refresh and Read LPL", "Clear and Read LPL", "Refresh and Read EPL", and "Clear and Read EPL" are present.
- Get PM Media Side LPL/EPL:** Includes a "Record Type" dropdown and checkboxes for "Media Side Lane SNR", "Media Side PAM4 LTP", "Tx Laser Bias", "Tx Power", "Rx Power", and "Per-Lane Laser Temperature". Buttons for "Refresh LPL", "Clear/Read LPL", "Clear/Read EPL", and "Refresh EPL" are present.
- Get Data Path PM LPL/EPL:** Includes a "Record Type" dropdown and checkboxes for "Frame Error Count" and "Media Side Pre-Side Ber". Buttons for "Clear and Read LPL" and "Clear and Read EPL" are present.
- Get PM Host Side LPL/EPL:** Includes a "Record Type" dropdown and checkboxes for "Host Side Lane SNR", "Host Side PAM4 LTP", and "Host Side Pre-Fec Ber". Buttons for "Refresh and Read LPL", "Clear and Read LPL", "Refresh and Read EPL", and "Clear and Read EPL" are present.

On the right side, there is a "Configuration" panel with "OSFP Analyzer" and "INITIATOR Mode" buttons, and a table listing various CDB (Control Data Block) entries:

Name	Page	Address	D
CDB status	00	37	
CDB complete flag	00	8	
Firmware download password	9F	136	
Copy/Abort/Full Image Reads	9F	137	
Start command payload size	9F	138	
Erased Byte	9F	139	
bsize	9F	140	
Write LPL / EPL	9F	141	
Read LPL / EPL	9F	142	
Run Image A or B hitless suppl	9F	143	
CMD Start 0101h max time m	9F	144	

At the bottom right, there is an "Export" button and a "Command Progress" section showing a progress bar and the status "Success".



## CDB Commands

- CMD 0000h Query Status
- CMD 0001h Enter Password
- CMD 0002h Change Password
- CMD 0003h Enable/Disable Password Protection
- CMD 0004h General Abort
- CMD 0380h Loopbacks

The screenshot displays the multiLane Analyzer software interface. At the top, there are tabs for 'Settings' and 'Help'. Below that, a 'Monitoring' section shows 'Adapter Temperature' at 21 and 'Analyzer Temperature' at 27. A 'Configuration' section on the right indicates 'OSFP Analyzer' is in 'INITIATOR Mode' with a 'Disconnect' button.

The main interface is divided into several sections:

- Monitor:** Includes tabs for 'FEC', 'CDB', 'Control Signals', 'R/W Functions', 'MSA Table', 'MSA Validation', 'Module Emulation', 'VCC', 'Current', 'I2C', 'Scope', and 'State Machine Analysis'.
- Features:** Includes 'Performance/Data Monitoring', 'Commands', and 'FW Download Command'.
- CDB Feature and capabilities Support:** A matrix showing support for various CDB commands across different modules (0, 3, 4, 7, 8, B, C, F).
 

Command	0	3	4	7	8	B	C	F
CMDs 0000h-000Fh	●	○	○	○	○	○	○	○
CMDs 0010h-001Fh	○	○	○	○	○	○	○	○
CMDs 0020h-002Fh	○	○	○	○	○	○	○	○
CMDs 0030h-003Fh	○	○	○	○	○	○	○	○
CMDs 0040h-004Fh	●	●	○	○	○	○	○	○
CMDs 0050h-005Fh	○	○	○	○	○	○	○	○
CMDs 0060h-006Fh	○	○	○	○	○	○	○	○
CMDs 0070h-007Fh	○	○	○	○	○	○	○	○
CMDs 0080h-008Fh	○	○	○	○	○	○	○	○
CMDs 0090h-009Fh	○	○	○	○	○	○	○	○
CMDs 00A0h-00AFh	○	○	○	○	○	○	○	○
CMDs 00B0h-00BFh	○	○	○	○	○	○	○	○
CMDs 00C0h-00CFh	○	○	○	○	○	○	○	○
CMDs 00D0h-00DFh	○	○	○	○	○	○	○	○
CMDs 00E0h-00EFh	○	○	○	○	○	○	○	○
CMDs 00F0h-00FFh	○	○	○	○	○	○	○	○
- Firmware Update Features Implemented:** Includes a 'Read FW Features' button.
- Table:** A table listing various CDB commands with their page, address, and data values.
 

Name	Page	Address	Data
CDB status	00	37	01
CDB complete flag	00	8	00
Firmware download password	9F	136	0
Copy/Abort/full Image Read/	9F	137	1
Start command payload size	9F	138	16
Erased Byte	9F	139	255
bsize	9F	140	255
Write LPL / EPL	9F	141	3
Read LPL / EPL	9F	142	0
Run Image A or B hitless supp	9F	143	0
CMD Start 0101h max time m	9F	144	3
- Export:** A button to export data.
- Command Progress:** A progress bar showing 'Success'.



## CDB Features

- CMD 0040h Module Features: Identifies which commands are supported, from CMD 0 to CMD 00FF along with the maximum CDB command execution time.
- CMD 0042h Performance Monitoring: Identifies which commands are supported from 0200h to 02FFh.
- CMD 0043h Bert and diagnostics: Identifies CMD 0300h to 03FFh.
- CMD 0041h Read FW Features: Identifies many parameters supported the firmware features including firmware download transfer type, if copy/abort/full image readback commands are supported, start command payload size, erased byte, the firmware update features, if read/write firmware is supported, the firmware can be upgraded, etc. Use this feature to determine whether a device supports LPL or EPL firmware.
- The green buttons indicate which commands are supported.

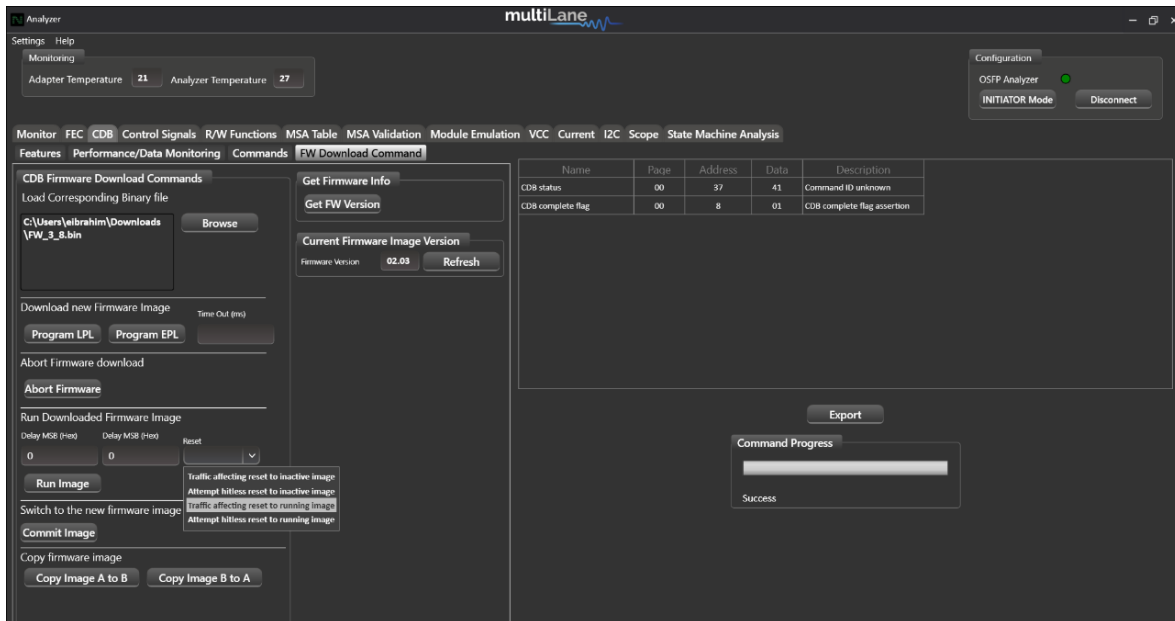

## CDB FW Download Commands

- CMD 0101h, 0103h, 0107h Program LPL: Loads the firmware binary file for Local Payload (LPL). Allows for updating interconnect firmware.
- CMD 0101h, 0104h, 0107h Program EPL: Loads the firmware binary file for Extended Payload (EPL). EPL support varies depending on the interconnect. Allows for updating interconnect firmware.
- CMD 0101h, 0105h, 0107h Read Image LPL: Read the latest upgraded firmware image using LPL
- CMD 0101h, 0106h, 0107h Read Image EPL: Read the latest upgraded firmware image using EPL.
- Export Image: Exports an image of the firmware after the read is completed as a .bin file, which in turn can be loaded into and read by other interconnects.
- CMD 0102h Abort FW download: Stops the firmware from being installed onto the interconnect.

- CMD 0109h Run image: After the new LPL or EPL Firmware is loaded, this command switches to the latest firmware image. Does not replace the existing firmware image on the interconnect.
- CMD 010Ah Commit image: Replaces the firmware image on the interconnect with the new loaded firmware image. Prior to this command being executed, the old firmware will still be executed on startup. Always ensure the new image is running perfectly (by running it on the interconnect using the previous commands) before using this command.
- CMD 0108h Copy image A to B/B to A: In the event of two images being present on the same interconnect and both images are written to flash, this command makes ensures that both images are identical, with the copied image being specified in the commands as either image A to image B, or image B to image A.
- CMD 0100h Get FW Info: Loads the information about the latest firmware on the interconnect, for both image A and image B.

## Control Signals

The control signals tab showcases the low-speed signals specific to each form factor, with the ability to drive them high or low. This tab operates in three modes, Initiator, Bypass and Target, effectively testing host and module side to validate each in regard to low-speed signals.

In Initiator mode, user can drive the low-speed signals of the module, validating that the module responds to host commands. In Bypass mode, user would be testing I2C between host and module. In Target mode, user can drive the low-speed signals on the host side, validating that the host responds to low-speed signals changes.

This tab allows users to validate I2C on both their host and module, and overall CMIS Compliance. For instance, user can change a control signal on their host, and validate its' change by placing Nexus in Target mode and reading the low-speed input and output signals.

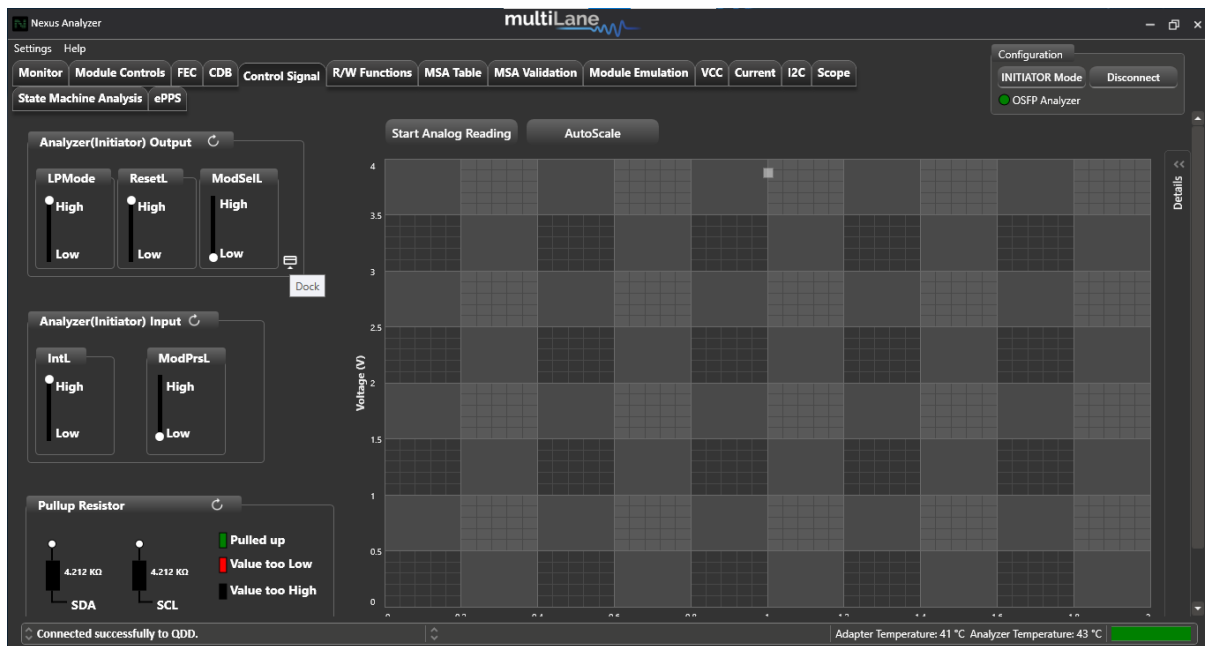

- Output/Input Signals:
- Read/ drive control signals
- Analog sampling of signals in real time

- Graph features vertical and horizontal markers.
- Pull up resistors: display SDA and SCL resistors values, where I2C should be in idle state to detect accurate values.
- Ability to export/import data
- Ability to dock Output Signals to the top of the GUI and control them throughout the application

Access to **OSFP** low-speed signals in three modes

Signals / Modes	LWPn	RSTn	INTn	PRSn
<b>Initiator</b>	Output signal	Output signal	Input signal	Input signal
<b>Bypass*</b>	No control	No control	No control	No control
<b>Target</b>	Input signal	Input signal	Output signal	Output signal

Access to **QSFP-DD** low-speed signals in three modes:

Signals / Modes	LPMode	ResetL	IntL	ModPrsL
<b>Initiator</b>	Output signal	Output signal	Input signal	Input signal
<b>Bypass*</b>	No control	No control	No control	No control
<b>Target</b>	Input signal	Input signal	Output signal	Output Signal

\*In bypass mode, Nexus only samples the signal between host and module.

## I2C Read/Write Operations

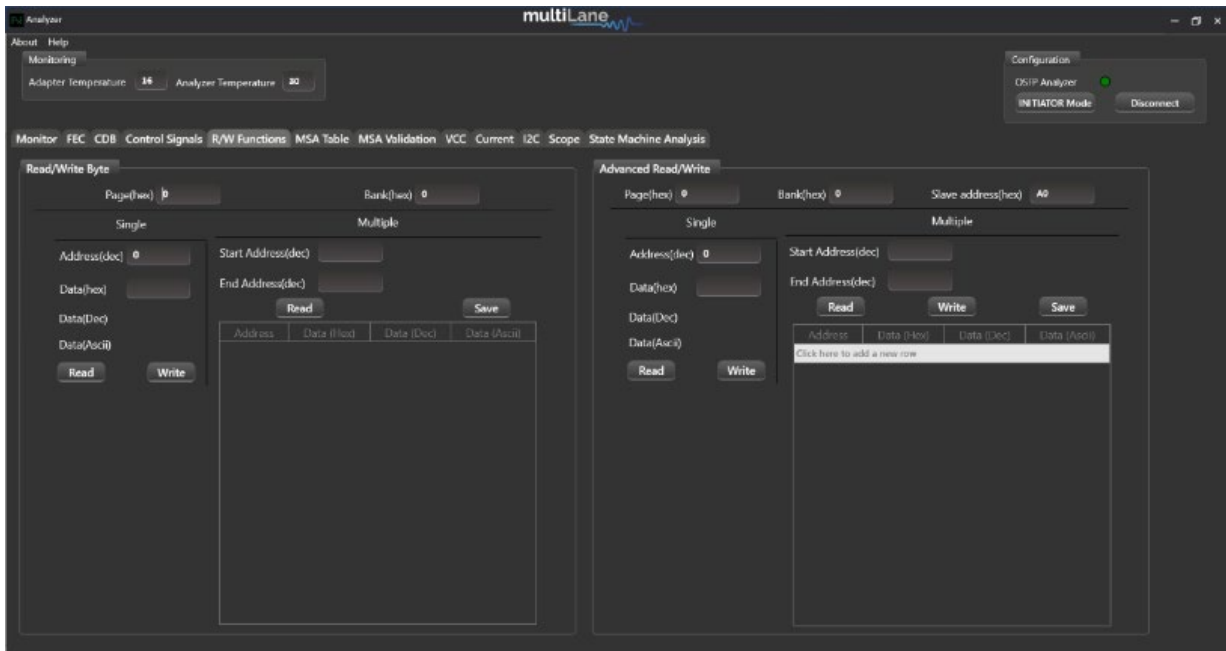

Operates in initiator mode

- Single byte read/write operations
- Multiple byte read operations
- Advanced R/W used to read from or write to multiple registers simultaneously

## MSA Table

The MSA Table tab works in Initiator mode, giving the user access to their Module Memory. Nexus will display the module memory, with address and description of each register. With a “Read Data” button, user can read the contents of every register in the module memory. In addition to reading, user can write or change the value of each register, by double clicking on the box of either the “Data (Hex)” or “Data (Dec)” columns of the desired register. To cement the changes, press on “Write Data to Hardware”.

Pages	Address	Data (Hex)	Data (Dec)	Data (Ascii)	Description	Read Only
Pages : LowMem - 128 Items						
LowMem	0		0		Identifier	<input checked="" type="checkbox"/>

The module memory can be read for all pages at once, or user can also filter the pages and read only a few at once. (link this to table that shows how to filter)

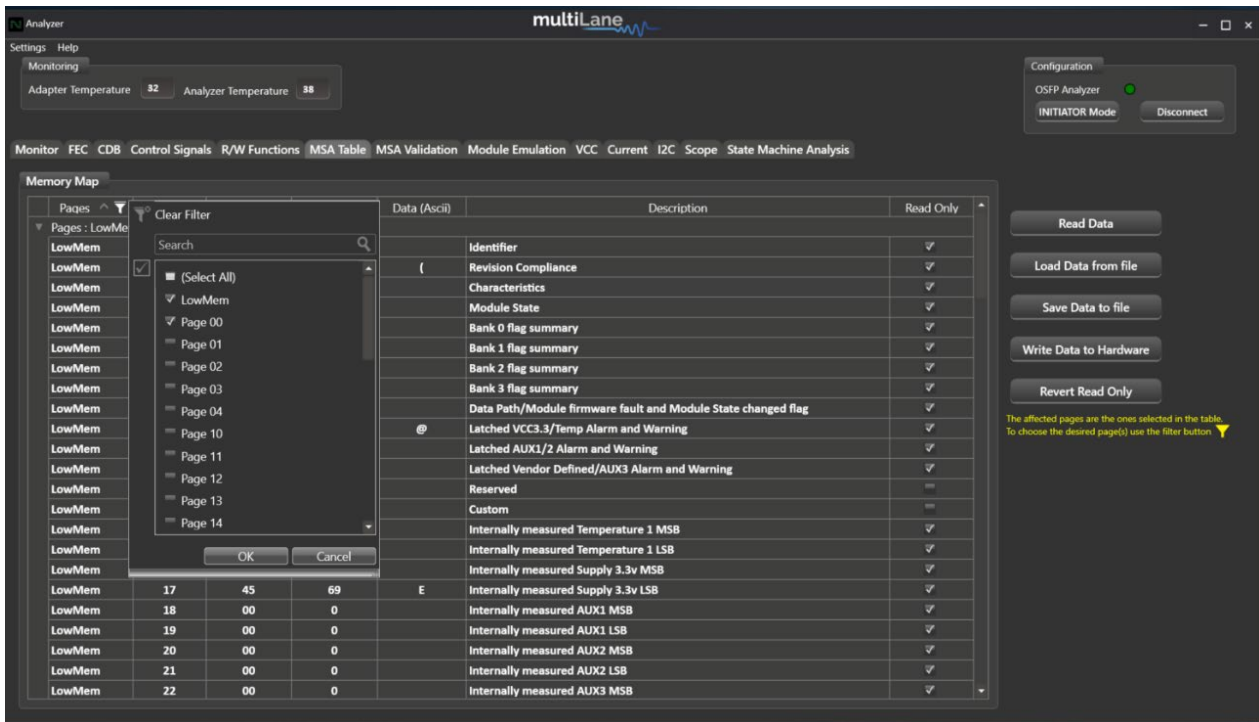

- Operates in initiator mode
- Select page(s) to read
- Read data from device for selected page(s)
- Save data to file
- Load data from file
- Write data to hardware to have the data required in respective addresses
- Read only column: checked boxes refer to read only registers, while unchecked boxes refer to read/write registers, as per MSA. Use these to make R/W registers RO, and RO registers R/W, affecting MSA compliance why?
- Revert read only: revert back to the original type access of all registers as per MSA

## MSA Validation

MSA Validation tab objective is to validate the CMIS implementation on the module, or the host.

On the Module side, MSA Validation works in initiator mode. User can select a standard:

- CMIS standard: user can validate module memory against the CMIS specifications.
- Custom standard: user can edit the CMIS specifications displayed by Nexus, or user can load their own custom standard. Further details explained below.

The user can validate their module memory in two different levels:

- Register level validation: Nexus will validate each register against the CMIS standard. If in that register one bit is writable, Nexus will consider the whole register to be writable and validate as such.
- Bit level validation: Nexus will validate the access type of each bit in every register, giving the user the respective details.

The levels are available for both CMIS and custom standards.

## Module side

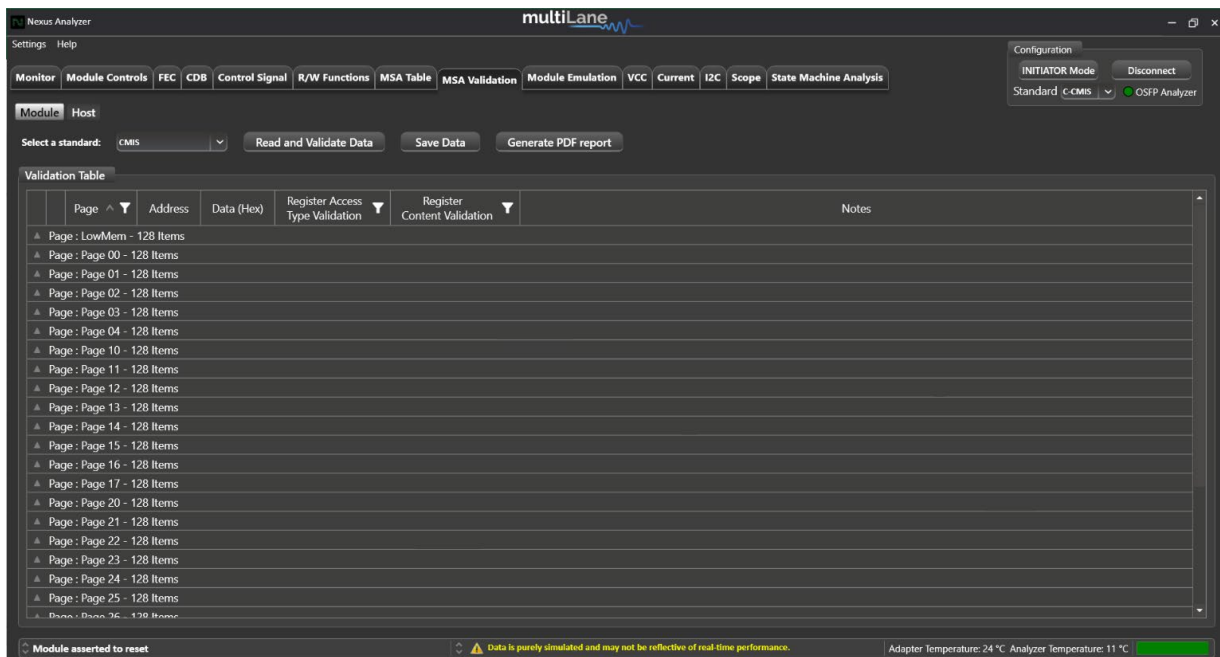

- Operates in initiator mode
- Select page(s) to read
- Read data from device for selected page(s)
- Select validation type: Register Access Type Validation or Register Content Validation, or both
- Validation on bit level available
- Validate data against selected standards:
  - CMIS: Nexus validates module memory map against CMIS specifications and standards. Bit level Validation available.
  - Custom: Nexus validates module memory map against user custom standards. Customization on bit level available.

- Save data to file
- Load data from file
- Generate PDF report for the selected page(s)

## CMIS VALIDATION

After validating the chosen page(s), a set of pass/fail registers appear as shown with the respective description of success or failure

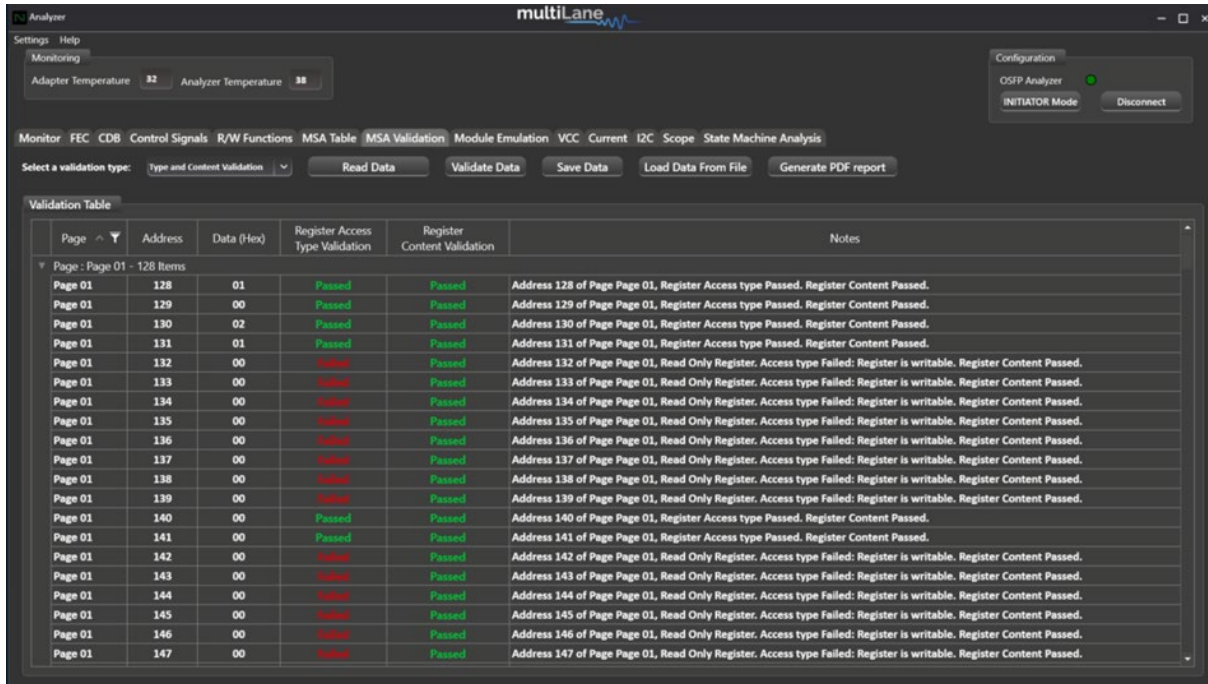

*One example reads:*

*Page 01, Address 136-*

*Register Access Type Validation: Failed*

*Register Content Validation: Passed*

*Notes: address 136 of Page 01, Read Only Register. Access type Failed: Register is writable. Register Content Passed.*

*According to the CMIS specifications, address 136 of page 01 should be Read Only in a compliant module. Nexus tries writing to the register and succeeds, resulting in a Fail on Register Access Type.*

## Bit Level Validation

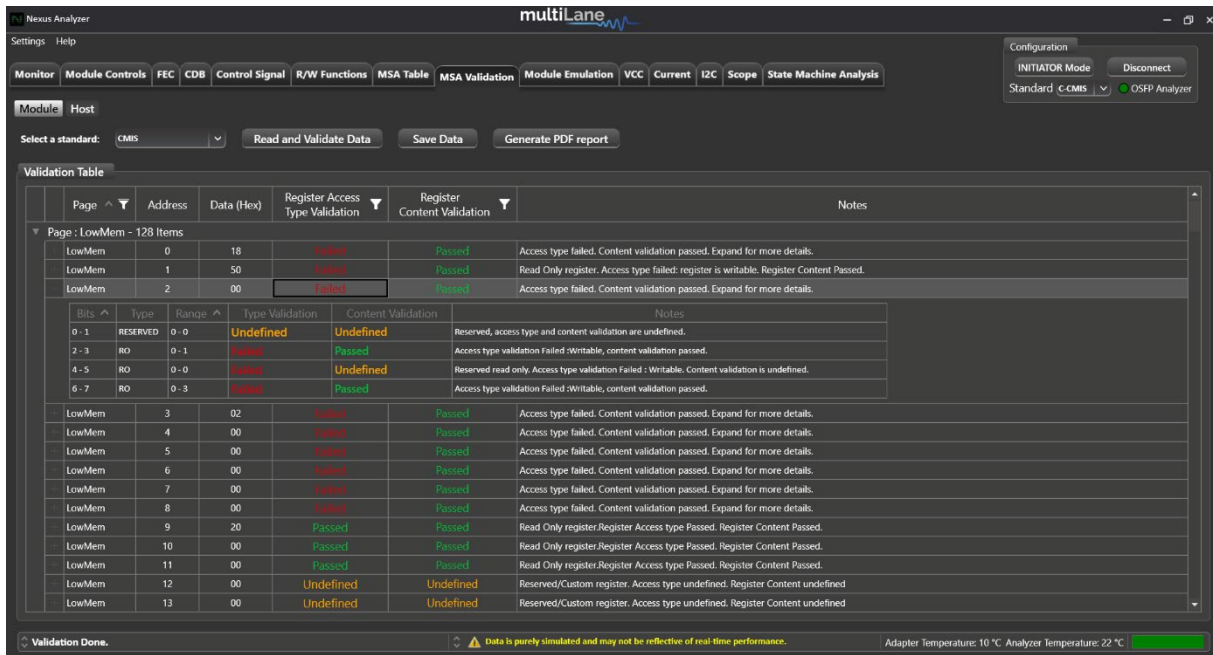

One example reads:

LowMem, Address 2-

Register Access Type Validation: Failed

Register Content Validation: Passed

Expand for more details:

Bits	Type	Range	Type Validation	Content Validation	Notes
0-1	RESERVED	0-0	Undefined	Undefined	Reserved, access type and content validation undefined
2-3	RO	0-1	Failed	Passed	Access type validation Failed: Writable, content validation passed.
4-5	RO	0-0	Failed	Undefined	Reserved read only. Access type validation Failed: Writable. Content validation is undefined.
6-7	RO	0-3	Failed	Passed	Access type validation Failed: Writable, content validation passed.



*When a register or a bit within that register are undefined as per CMIS, Nexus validates them as such.*

*Otherwise, each bit or pair of bits are validated against their Type, and Content specifications as per CMIS.*

## Custom Validation

The CMIS memory map includes registers and bits that are open to customization. In addition, a user may want to customize a few registers to their liking, effectively not fully complying to the CMIS standards.

In this case, Nexus allows users to upload their own standards as .CSV files, or allows them to edit the CMIS memory map directly on the software, as shown in the example above and to follow.

Custom Validation is available on register and bit level, the below example follows the bit level custom validation of address 2, LowMem.

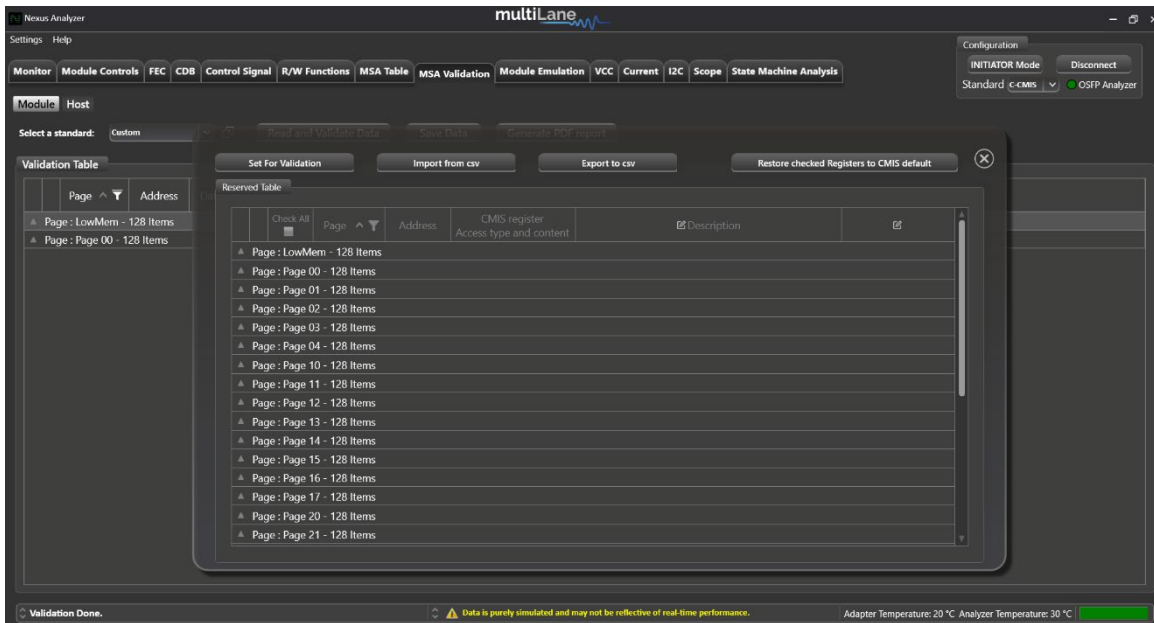

Follow the example below:

Select LowMem as shown below, to start with:

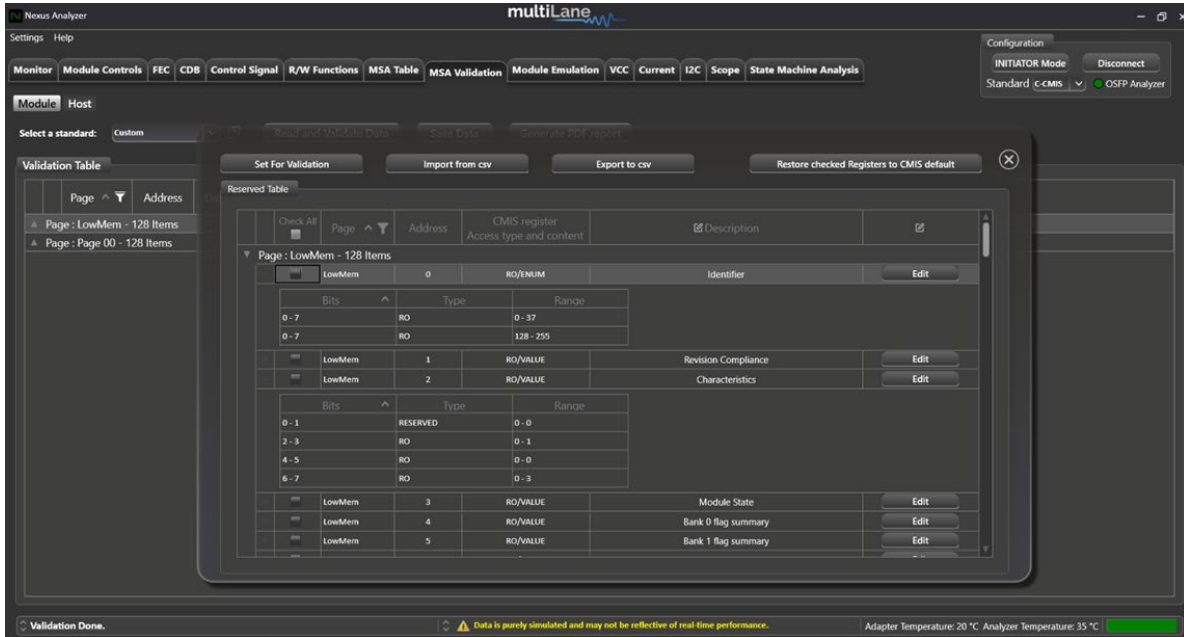

Selecting LowMem, address 2 to edit and customize as shown below:

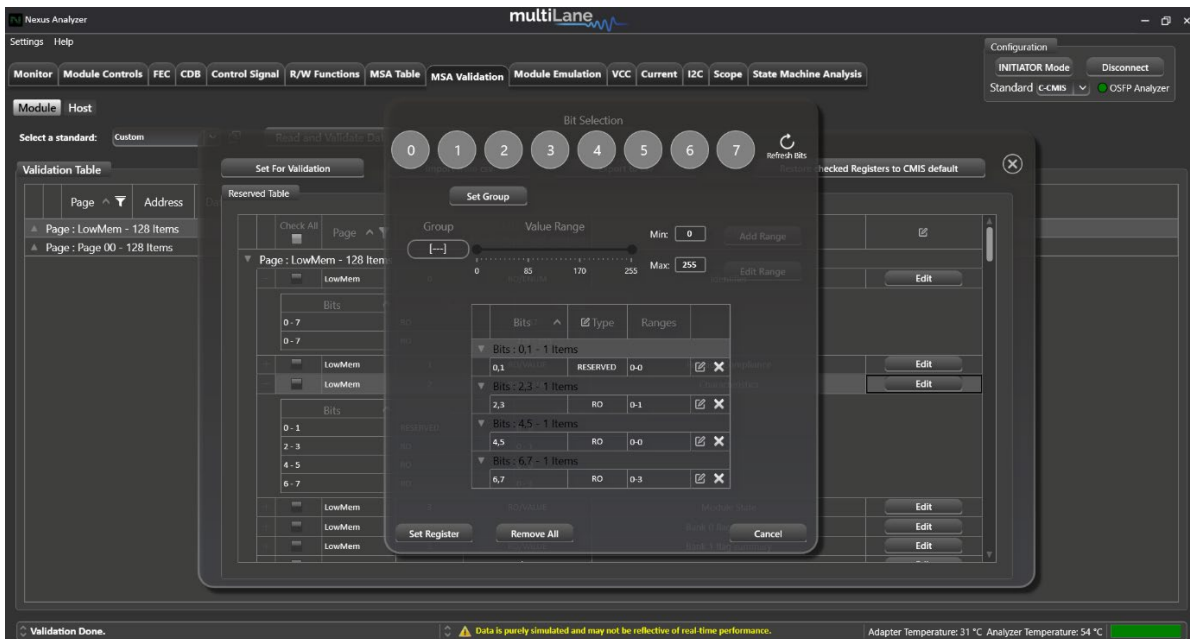

Upon selecting the register to customize, the window shown in the photo above will appear, showcasing the following:

- Accessible Bits 0-7: select which or all bits to customize
- Editable Value Range of register: customize value range of selected bits
- Editable Access type and ranges of each of the bits

### Select bits to customize

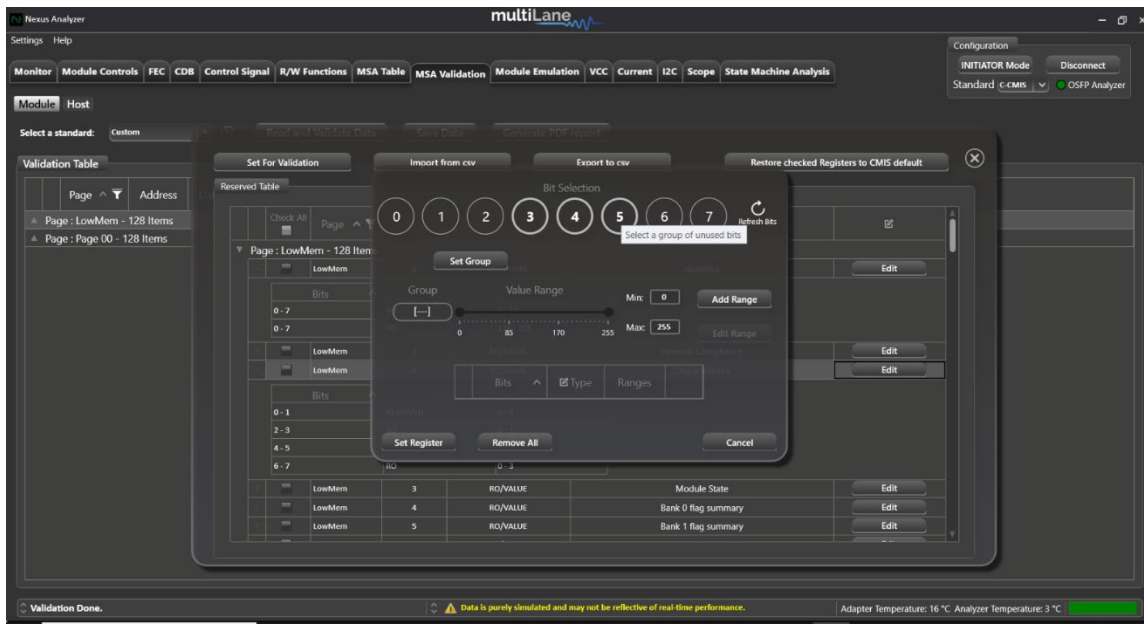

### Select range of values for selected bits

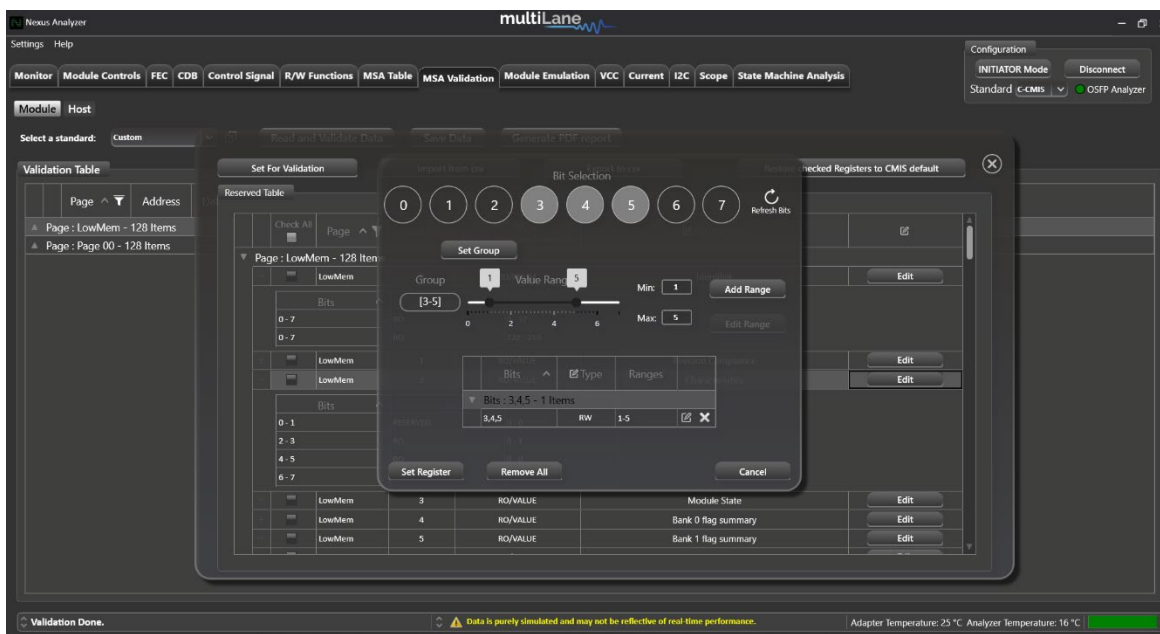

*Edit access type and range through the table*

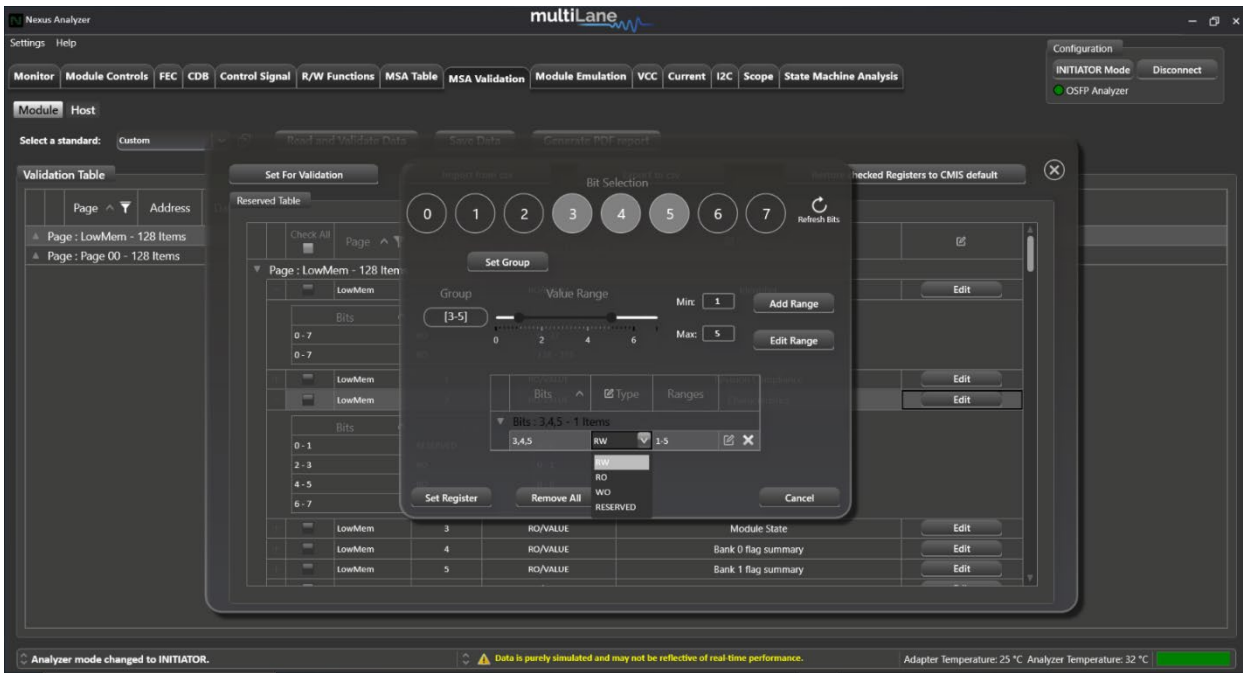

*In the photo shown above, user can change the access type of each standalone bit, or group of bits.*



*In the photo shown above, user can edit the range of values from the table*

*Upon reading and validating the data, user will get a set of pass/fail registers against their customized standards*

## MSA Validation

### Host Side

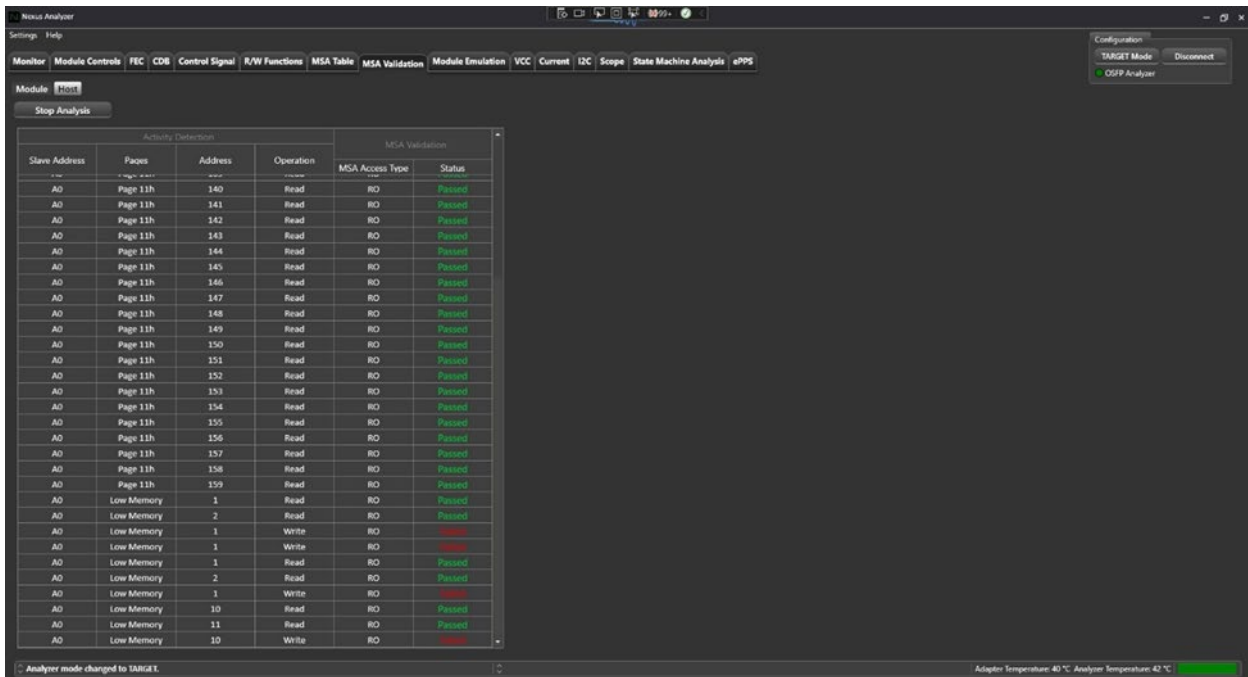

On the host side, this tab operates in Target mode. From the host side, the user can send out R/W operations to the module, and Nexus will validate these operations and registers involved as shown above.

Press on “Start Analysis”, go to host UI, and send out commands. Nexus will show you the page and register, the type of operation, and will show you as per CMIS standards the access type of each of those registers, with a pass/fail according to CMIS.

Press on “Stop Analysis” once testing is done.

## Module Emulation

Module emulation works in target mode, where Nexus emulates a module memory as per CMIS. It allows you to validate the host register access, by confirming that the host is adopting the proper access types (RO/RW) for CMIS specific addresses.

Module Emulation also allows user to emulate Module monitored parameters including temperature and signal loss, validating that your host is monitoring correctly.

## Memory Map

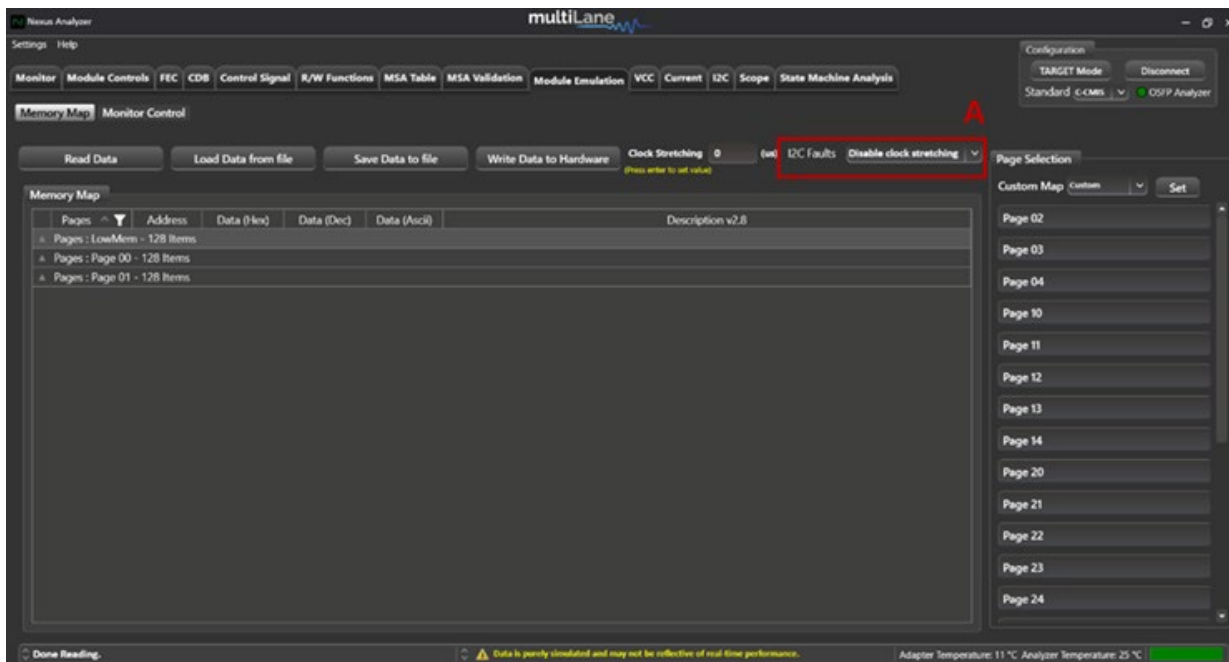

### Emulate Module Memory:

- LowMem, Page00 and Page01 are emulated by default in **“Memory Map”**
- Under **“Page Selection”**, user can add a maximum of three extra pages to emulate by dragging and dropping under **“Memory Map”**, or simply clicking on the page.
  - Once user adds a page to the emulated module memory, edit or write to the registers directly in the **“Memory Map”** table by double clicking on the **“Data(Hex)”** column and typing a value:

Pages	Address	Data (Hex)	Data (Dec)	Data (Ascii)	Description v2.8
Pages : LowMem - 128 Items					
LowMem	0		25		Identifier
LowMem	1	28	40	(	Revision Compliance
LowMem	2	04	4		Characteristics

- Commit the value by pressing **“Write Data to Hardware”**
- Write to memory directly on the table and commit by pressing **“Write Data to Hardware”**
- Validate the host R/W capabilities by reading the changed register from the host side

- Nexus FW will continue emulating the pages added until or unless the page/pages are removed. If the pages are not removed, expect the same pages to reappear after Nexus GUI disconnection. To remove the pages added, press on the “X” icon next to the added pages under “Page Selection”:

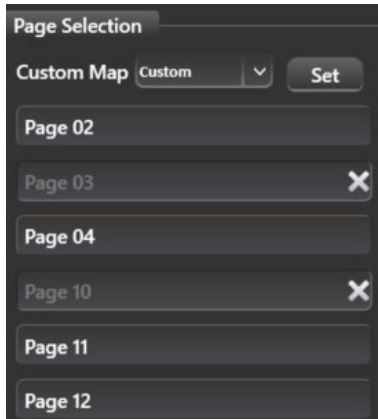

- Option to emulate a MultiLane custom memory by choosing one of the following under “Page Selection => Custom Map”:
  - Active Electrical Cable (AEC)
  - Active Loopback (ALB)
  - Passive Electrical Loopback (ELB)

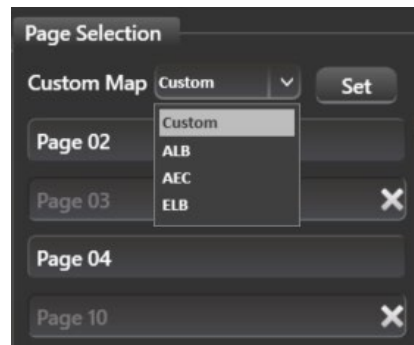

---

### Validate Host

---

- Access the host to validate it is reading/ writing correctly to emulated module memory
- Carry out R/W operations from the host side on the registers changed from Nexus side

---

### Module Emulation Tab Also Allows User to:

---

- Change Clock Stretching
- Choose and add an I2C Fault Trigger (Choose “Reset I2C” to remove fault):
  - Expect communication to be interrupted by I2C fault triggers from Host side, for example choosing a “Single Read” I2C Fault will interrupt the Host from reading a single register

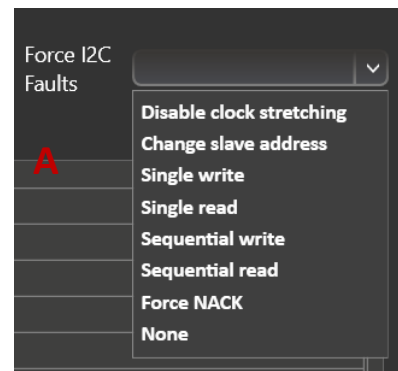

## Module Control

Emulate module parameters as below, and validate your host monitoring capabilities:

In addition to emulating output power, temperature and VCC supply, you can also trigger alarms and warnings.

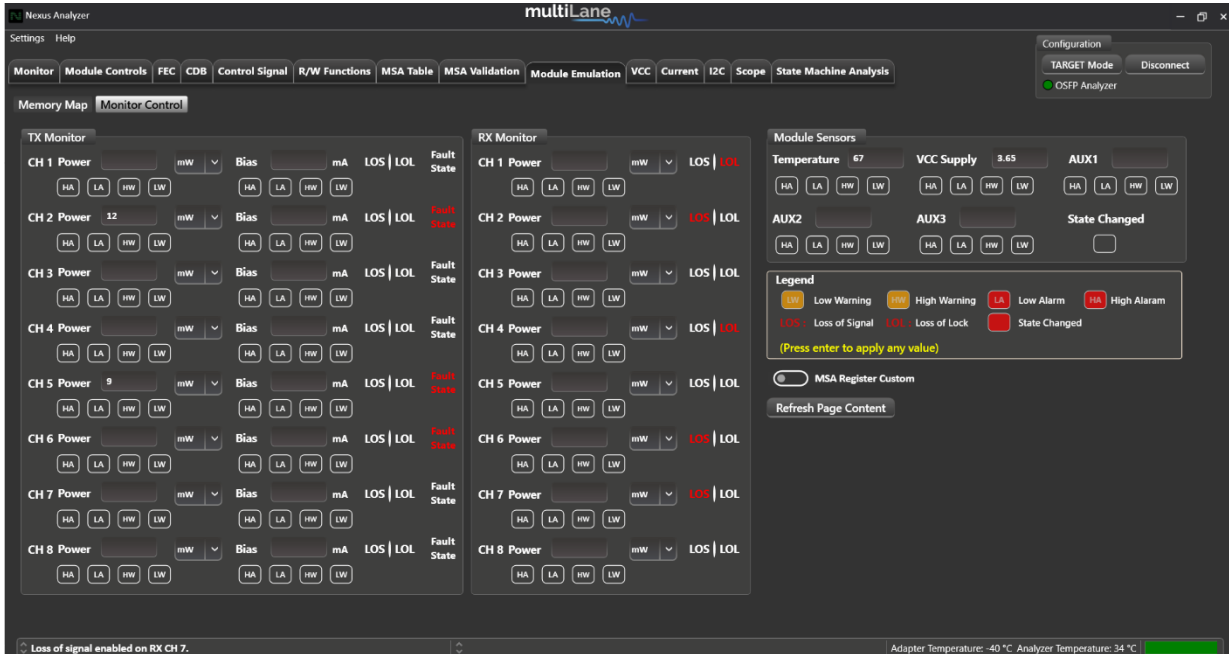

Press “Refresh Page Content” to refresh the content of the page.

Enable “MSA Register Custom” to reset the alarms and warnings and making them abide by CMIS standards of warnings/alarms type. Some of these are standardized as “Clear On Read”, so enabling MSA Register Custom will clear these warnings and alarms being monitored or read from your host. Disabling “MSA Register Custom” is customizing their type as “Read Only”, giving user access to emulate alarms and warnings as desired. After disabling “MSA Register Custom”, press “Refresh Page Content”



## Graphs and Measurements

Nexus allows for the measurement of real-time VCC supply, In-rush and continuous current, I2C communication, and real time probing of voltage, current, SDA and SCL signals. All graphs and measurements are configured in the same steps, listed below:

The below example was done on the VCC tab, and applies to the Current tab, I2C Tab, and Scope Mode tab.

The Log Size of the data is set by default to 60 seconds, and can be increased by accessing “Settings => SW parameters” on the top left of the GUI.

### Data Configuration

- Set your required sampling speed

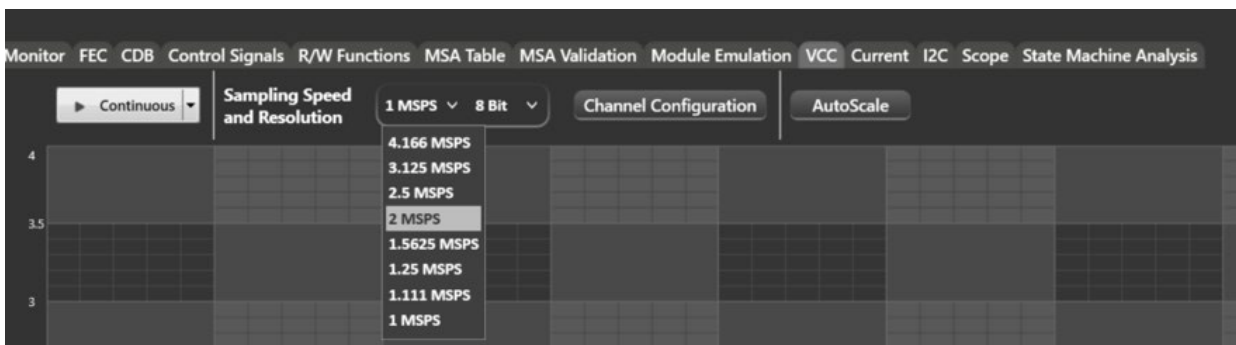

- Set your required sampling resolution

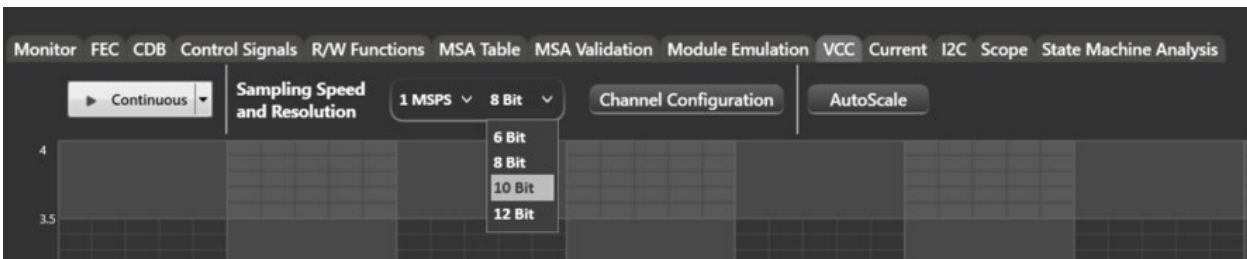

- Set your channel configuration

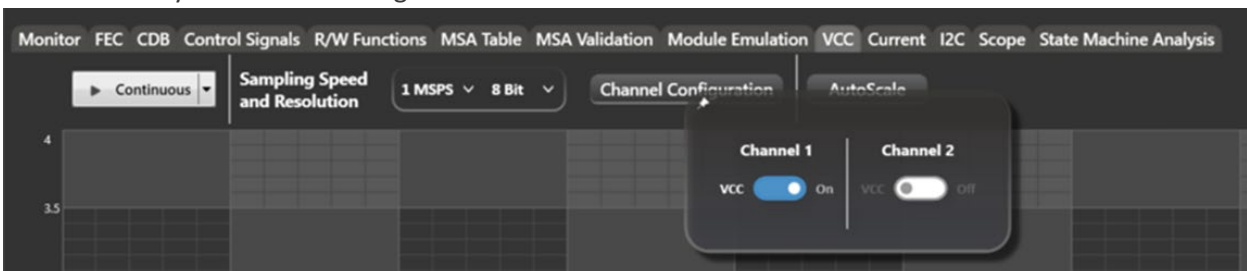

- Once the measurement is done, expand the Details window as below:

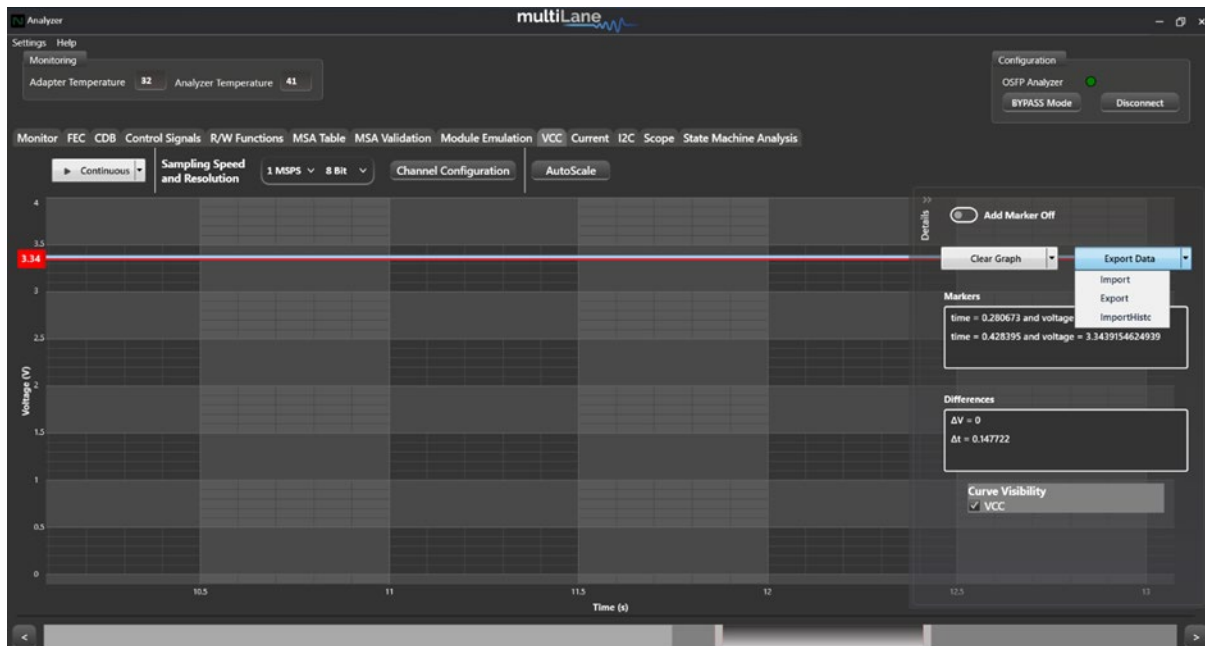

- Add Marker: go back to the graph and press on any point directly onto it to add your marker.
  - “Markers” box indicates the time and voltage marker values
  - Differences” box indicates the difference by voltage and time between markers
  - Clear graph:
    - Data: clear all markers
    - Graph: clear all captured data
  - Export data:
    - Import: import a single file to visualize data on graph. A single file is the portion of data visible on the screen.
    - Export: export data and save file. Export file previously imported.
    - Import History: import all the data measured from the start of the session.

## Graph Timeline

After capturing data in continuous mode for a large interval of time, you can use the graph timeline as shown below, to focus the data on a specific interval of time.

Hovering over the timeline you will see the data is categorized into cached data, and session data.

Cached data offers real time reading of data, while session data is saved into files which we have to access to read

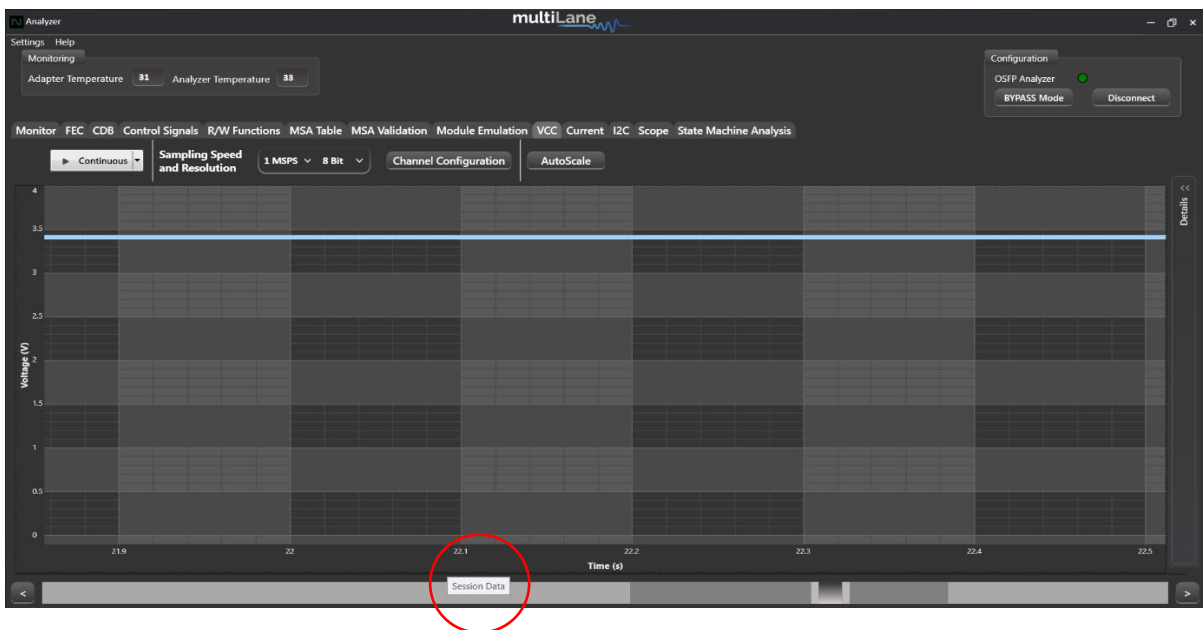
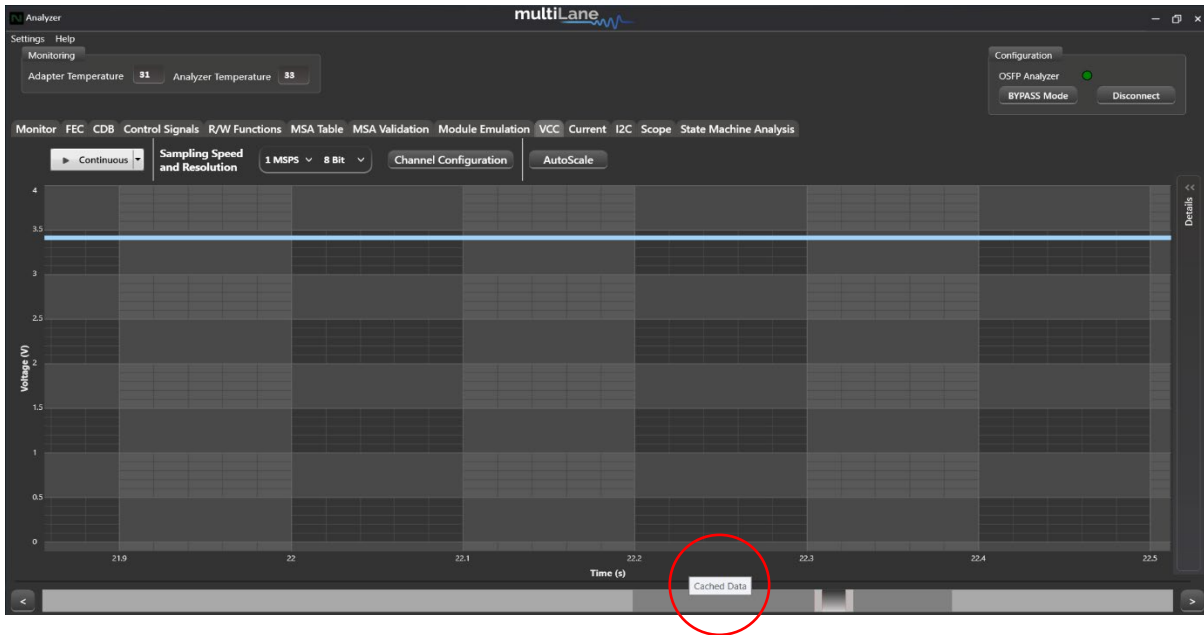

## VCC Measurements

VCC Measurements can be done in initiator, bypass or target modes.

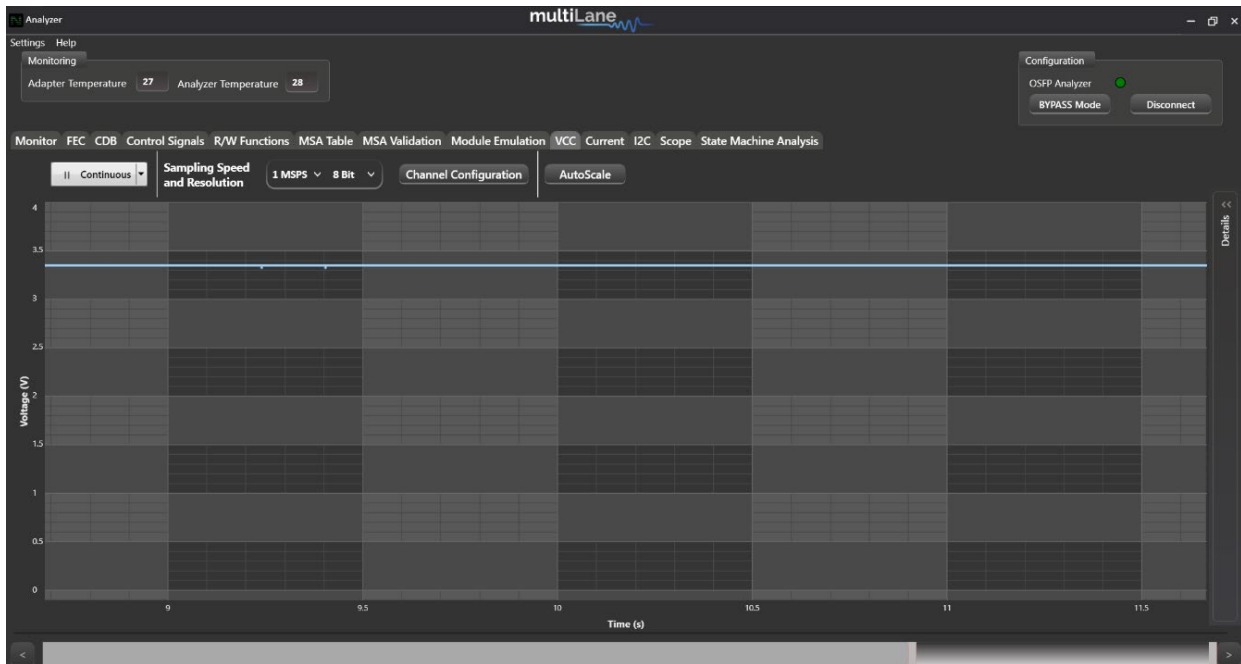

Measure VCC in continuous mode, or measure VCC spikes, by configuring the sampling speed and resolution, as well as the channels:

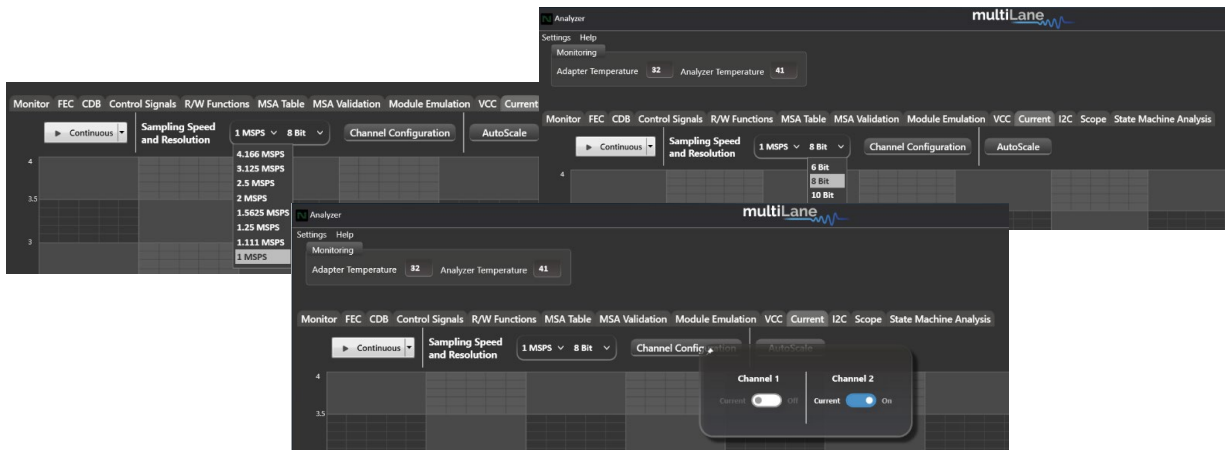

Once your configuration is done, press “Continuous” to get the data.

## Current Measurements

Current Measurements can be done in initiator, bypass or target modes

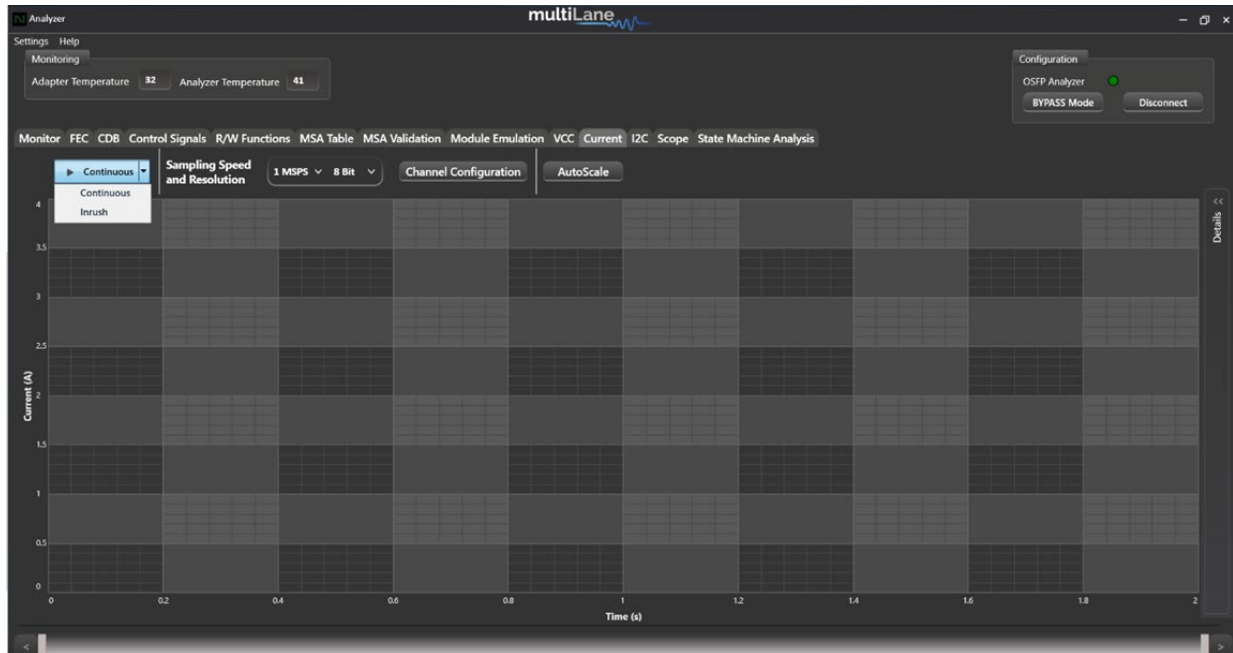

Choose your required current measurement:

- Continuous current measurements
- In-rush current measurements

Set your sampling speed and resolution, and configure the channels:

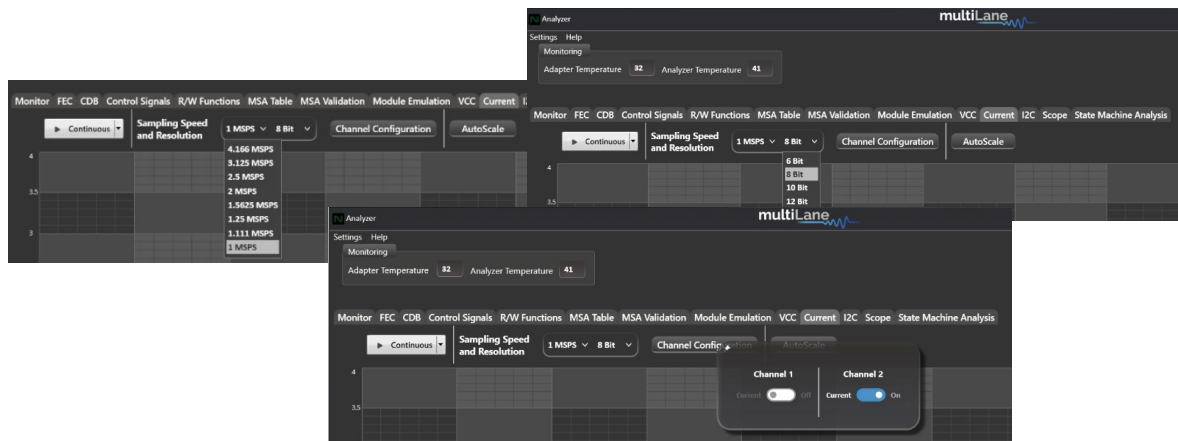

## In-rush current measurements

- Nexus should be in Initiator mode
- DUT should be unplugged from Nexus
- To capture in-rush current upon module power-up, start capturing while DUT is unplugged, and plug in DUT once you start capturing data. (shown below)

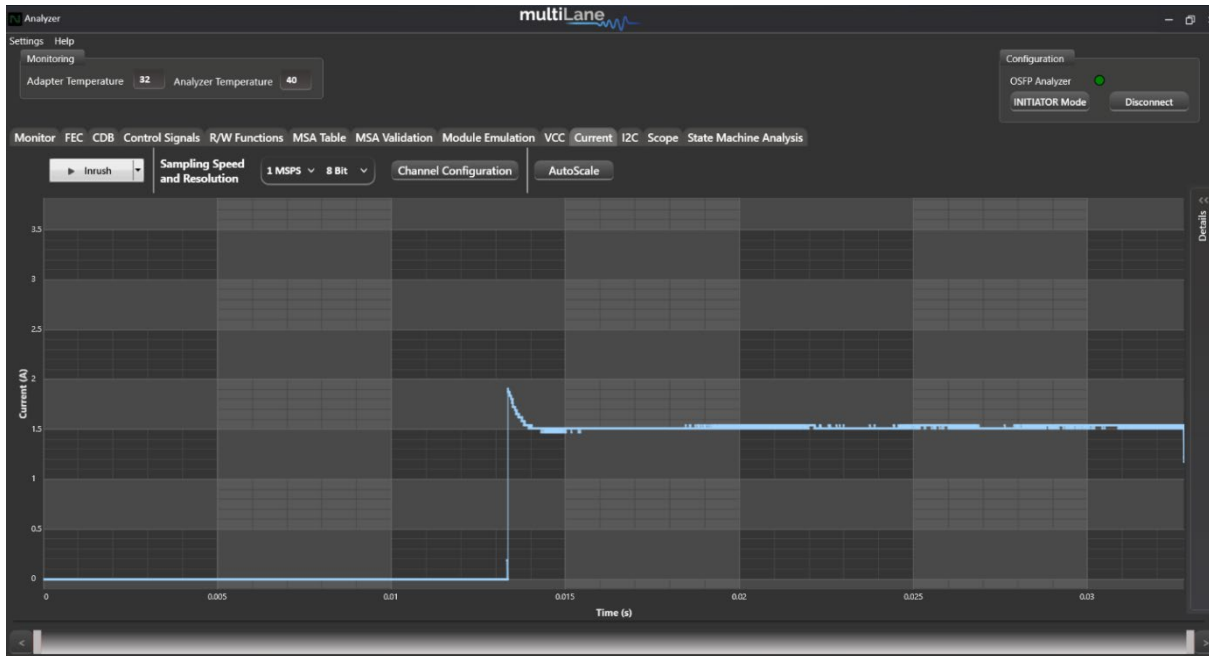

## I2C Packet Analysis

- I2C Captures can be done in initiator, bypass or target modes
- Single and continuous captures
- I2C trigger and tracking events
- Different sampling speeds available
- Represent SCL, SDA, ACK/NACK, and I2C edges graphically

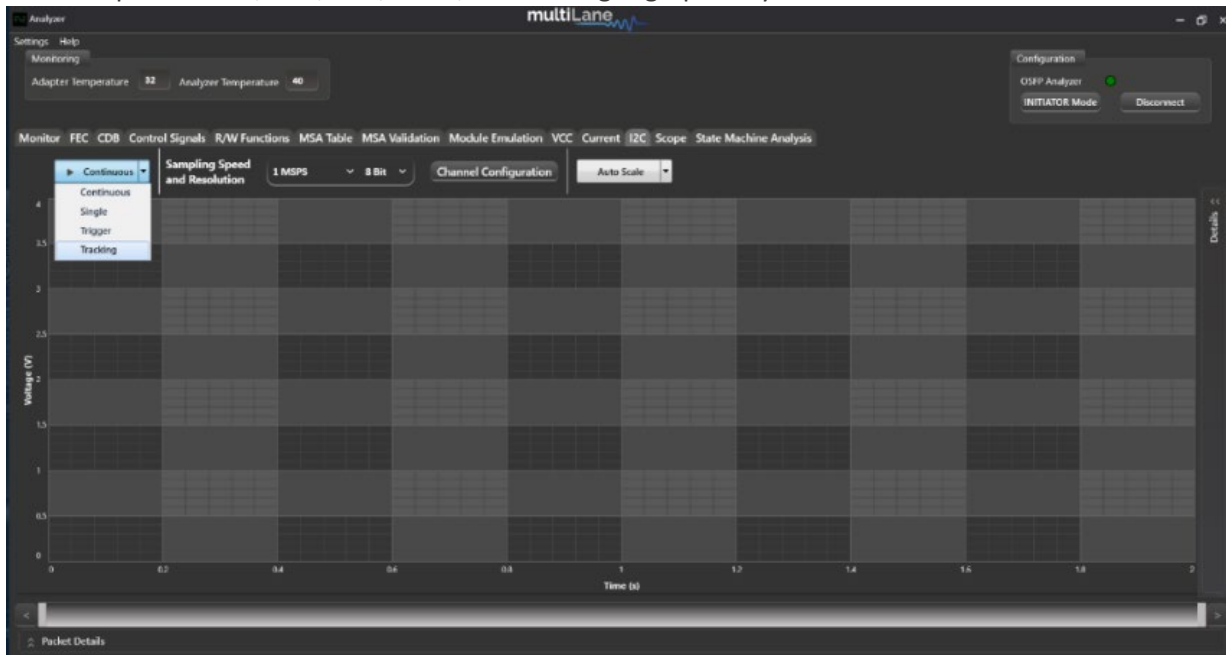

Configure the sampling speed, resolution and choose channels:

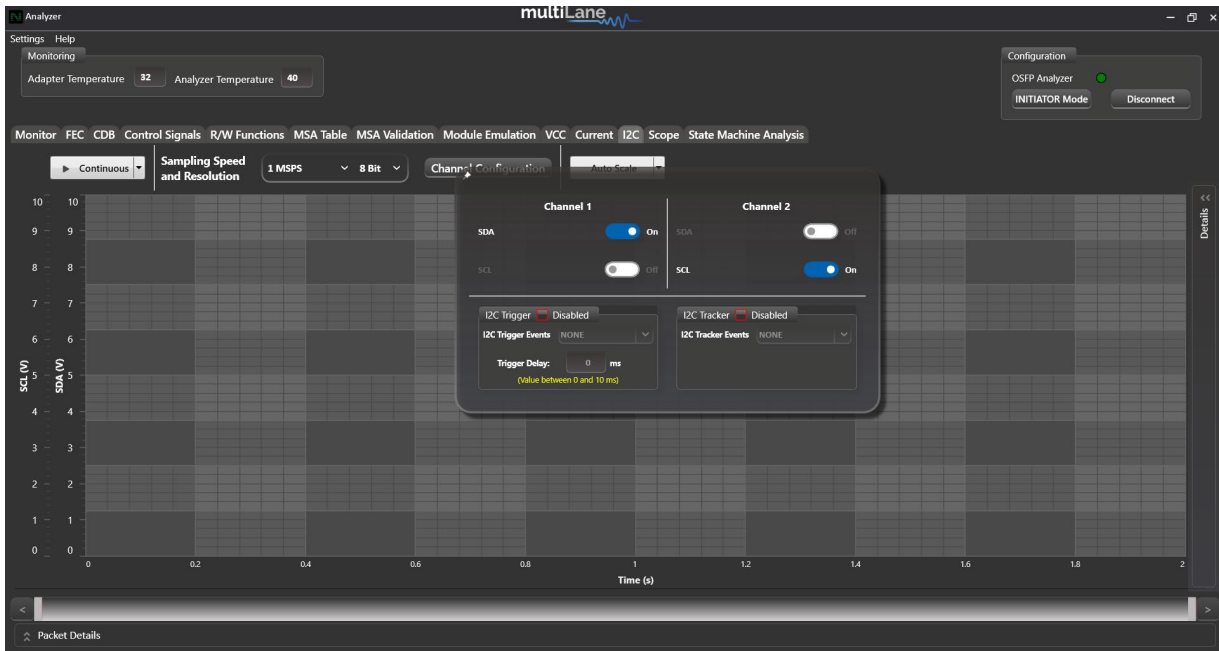

### Continuous Capture

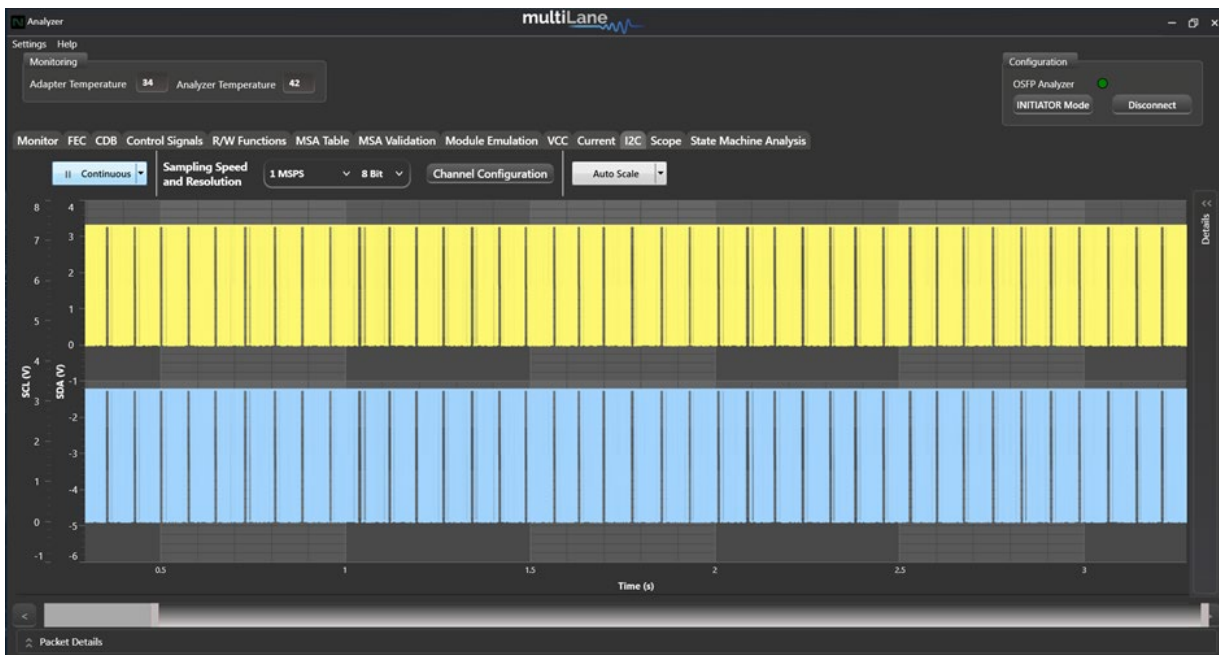

I2C continuous capture shows SDA and SCL data.



## Single Capture

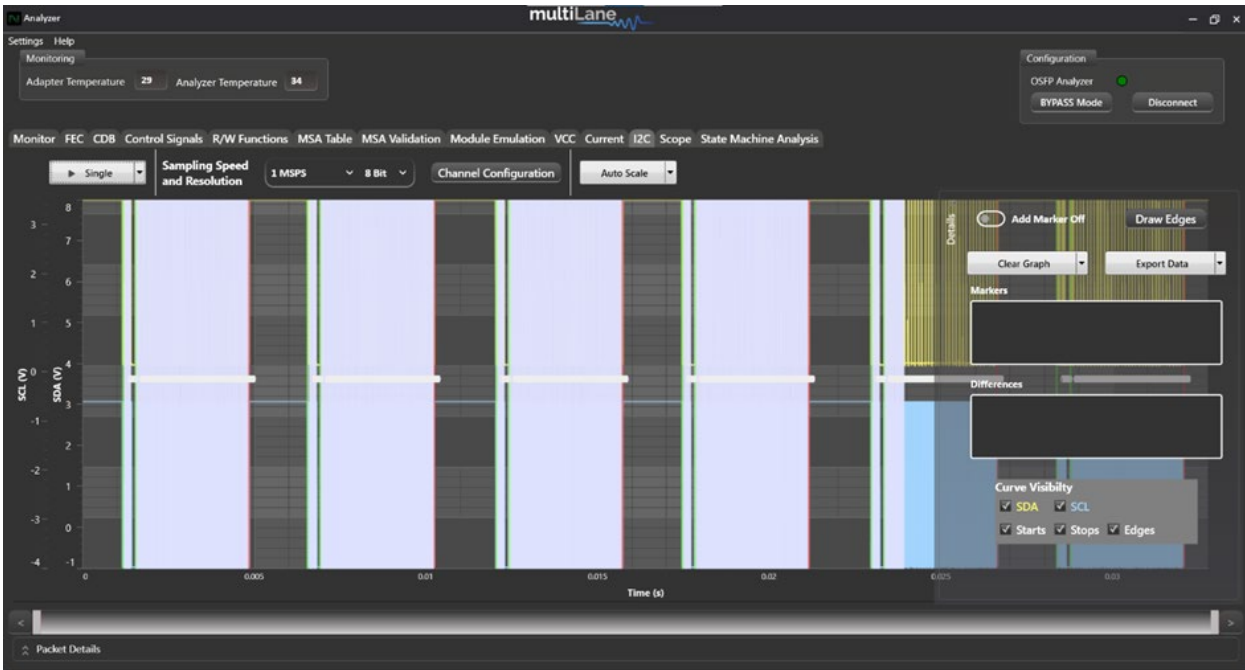

I2C Single, trigger and tracking captures show SDA, SCL, Start, Stop and Edges on the graphs.

## I2C Trigger Capture

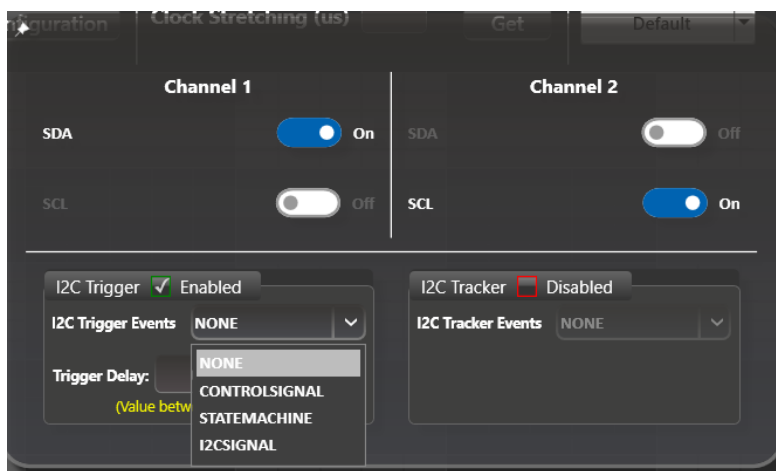

Trigger I2C with:

- Control Signals:
  - Module Interrupt
  - Module Present
  - Reset
  - Low Power
- State Machine
- I2C Signal:
  - Start
  - Stop

Choose the trigger required and measure the data:

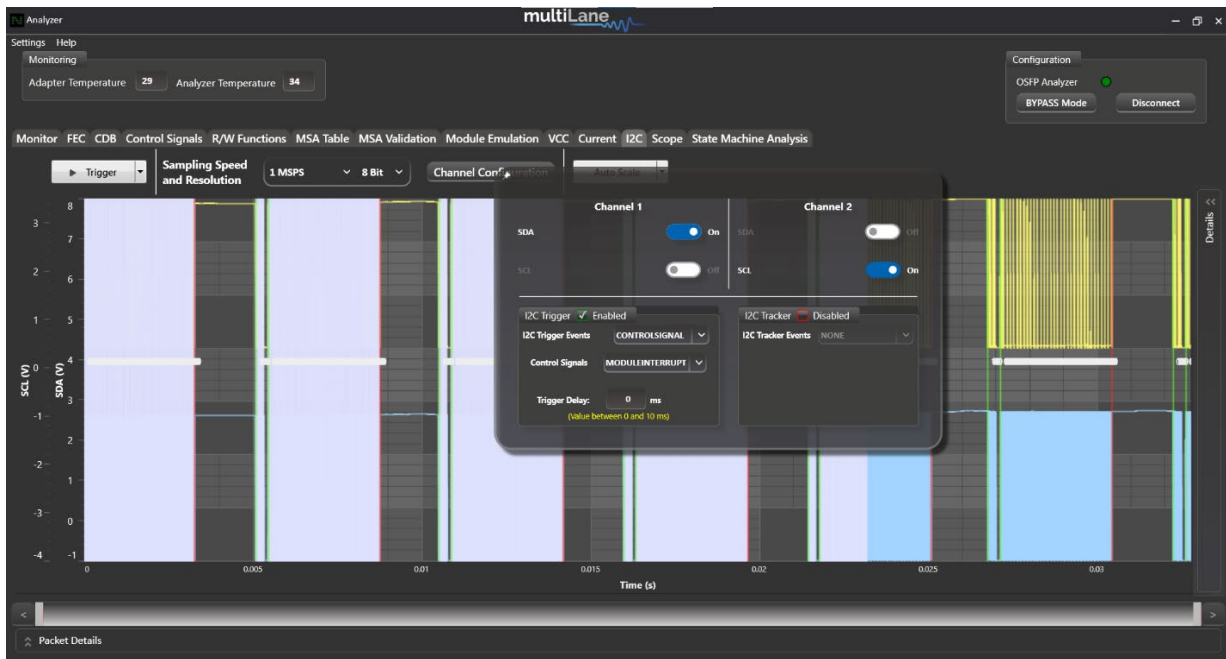

## I2C Tracking Capture

Indicate which address you want to capture, and if you'd like this data tracked.

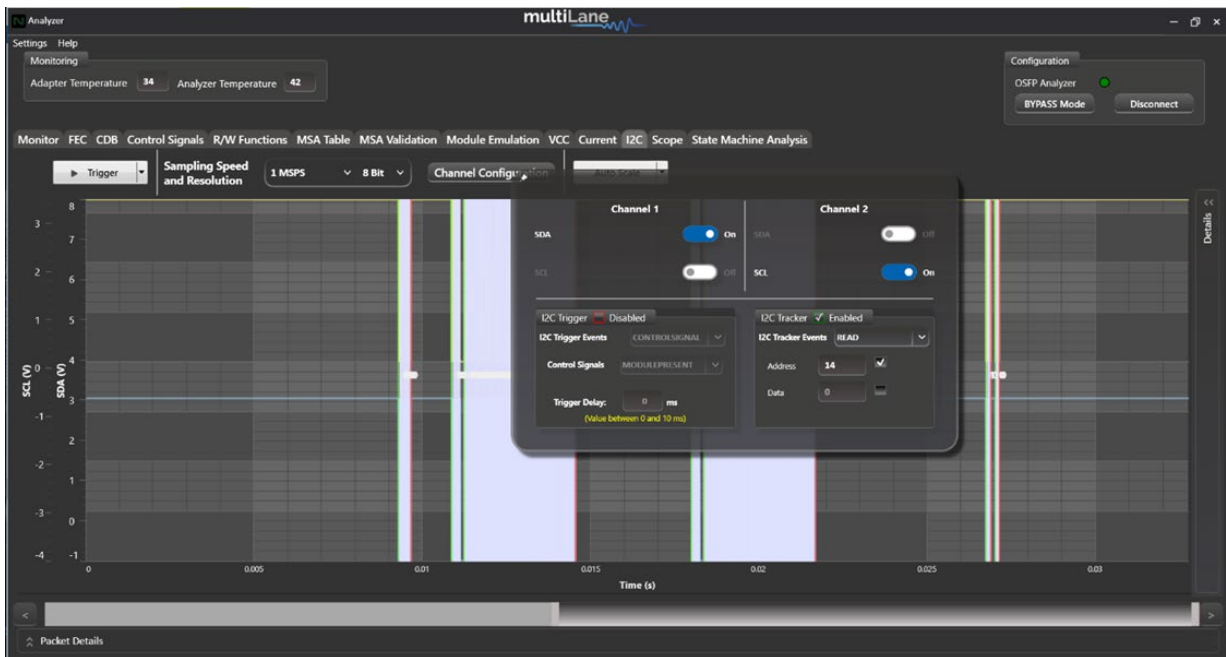





Configure your sampling speed and resolution, and move on to the channel configuration:



Choose to measure two signals from two different channels at once, choosing between:

- SDA
- SCL
- Current
- VCC

Measure the continuous data

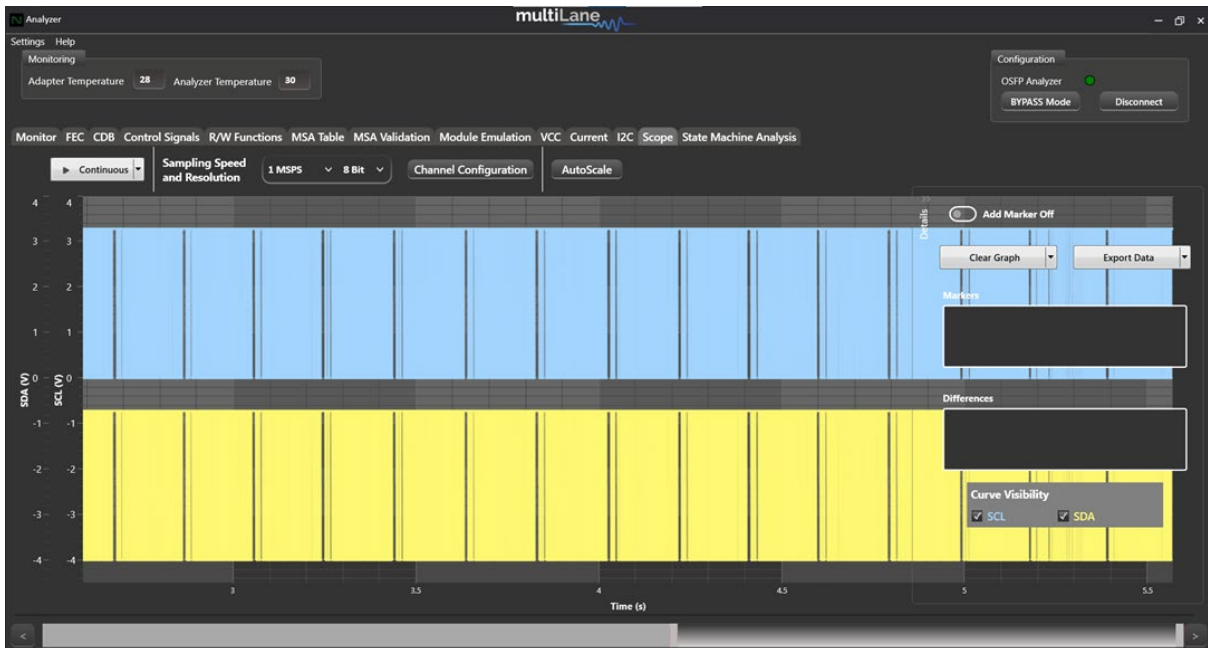

## State Machine Test

All tests below are equipped with detailed logging on time and state transitions, which can be generated into a PDF report. All the tests and state transitions are manually driven: take the module from one state to another by manually pressing on the desired state transition (the below tests are not automatic)

For the below state machine tests, it is possible for the user to override state transitions CMIS time limitations. Press “Set Duration”, and check “Override CMIS limits”. Control the slider to the time range required.



The state machine tests include:

- Module State Machine test
- Data Path State Machine test
- Module Behavioral Model
- Network Path State Machine test

The tests are all **manually driven** and are available on module side in initiator mode, and host side in target mode.

On the module side, Nexus would be validating module state transitions, testing that a module receives and acts on a host state transition command accordingly.

On the host side, Nexus would be validating the host commands. User can initiate these commands from the host side, and validate them from the logs that come with the test on Nexus side.

We recommend to check the modules power up sequence as tests will fail according to the power up sequence advertised in the module.

### Module Side

The below tests are all done in initiator mode. The tests are each initialized by clicking on the desired test, and pressing on “Initialize Test”:

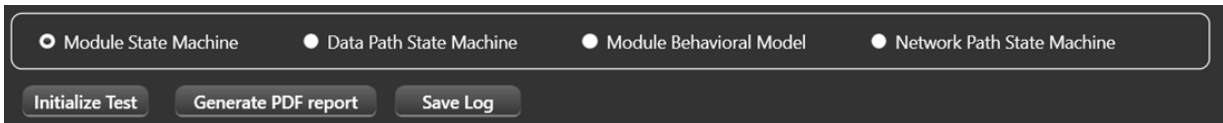

For the below state machine tests, it is possible for the user to override state transitions CMIS time limitations. Press “Set Duration”, and check “Override CMIS limits”. Control the slider to the time range required.

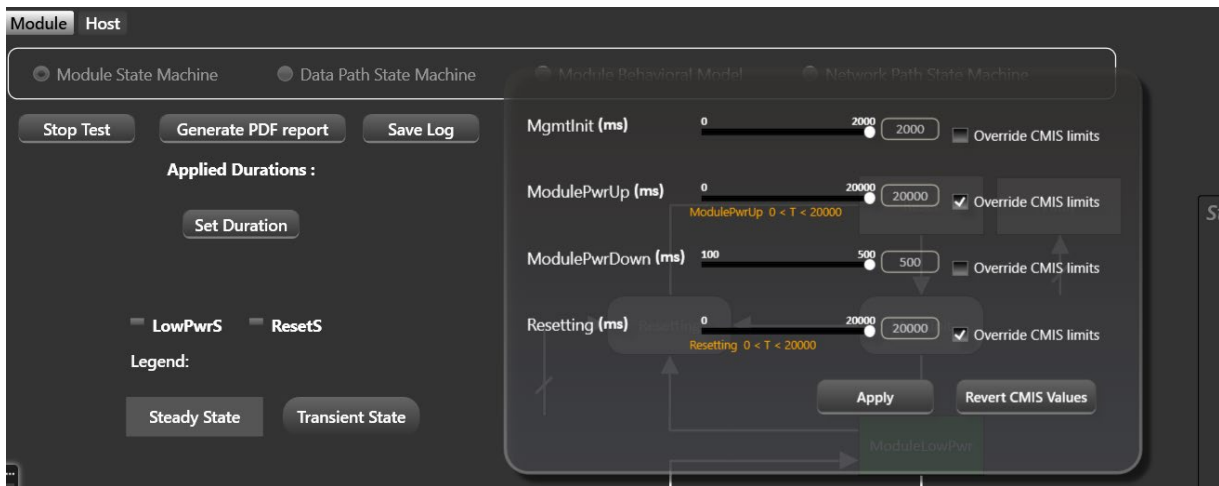

To manually drive the tests, user can press on the rectangles in the block diagram:

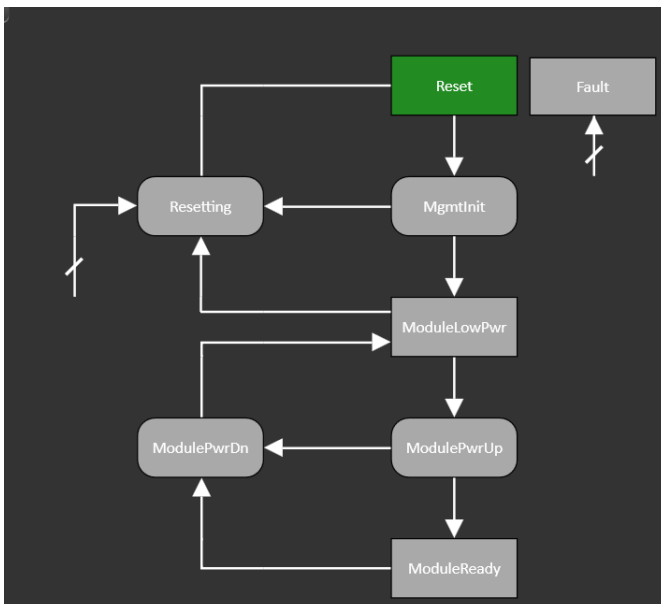

The example above is taken from a Module State Machine test, and user can drive the module from and to any state including Reset, ModuleLowPwr and ModuleReady. If the state transition is successful, the designated rectangle or block of the new state turns green. If the state transition has failed, the test will go to a “Fault”, with details of the fault in the logs, as shown below:



Stop the test by pressing “**Stop Test**”. All test logs can be saved to a text file by pressing “**Save Log**”, and can be generated into a PDF report by pressing “**Generate PDF report**”:

### Module state machine test



## Data path state machine test

The screenshot displays the Nexus Analyzer interface for a Data Path State Machine test. On the left, a log window shows the following entries:

```

[2023-05-24T11:20:20]: Data path InitPendingLane<1> DPinit not yet executed
[2023-05-24T11:20:20]: Data path InitPendingLane<2> DPinit not yet executed
[2023-05-24T11:20:20]: Data path InitPendingLane<3> DPinit not yet executed
[2023-05-24T11:20:21]: Data path InitPendingLane<4> DPinit not yet executed
[2023-05-24T11:20:21]: Data path InitPendingLane<5> DPinit not yet executed
[2023-05-24T11:20:21]: Data path InitPendingLane<6> DPinit not yet executed
[2023-05-24T11:20:21]: Data path InitPendingLane<7> DPinit not yet executed
[2023-05-24T11:20:21]: Data path InitPendingLane<8> DPinit not yet executed
[2023-05-24T11:20:21]: Data path State is : DPACTIVATED
Elapsed time: 318ms
    
```

In the center, a state machine diagram shows the following states and transitions:

- DPDeactivated** (grey) transitions to **DPinit** (grey).
- DPinit** (grey) transitions to **DPinitialized** (grey).
- DPinitialized** (grey) transitions to **DPtxTurnOn** (grey).
- DPtxTurnOn** (grey) transitions to **DPActivated** (green).
- DPActivated** (green) transitions to **DPtxTurnOff** (grey).
- DPtxTurnOff** (grey) transitions to **DPDeinit** (grey).
- DPDeinit** (grey) transitions to **DPDeactivated** (grey).

On the right, configuration options include "Max Transition Time: (ms)" set to 5000 and a "Legend" with "Steady State" and "Transient State" indicators.

## Module Behavioral Model

Access the Appsel codes supported on your DUT through the Module behavioral model. The supported Appsel Codes are highlighted as shown below for Application 1 and Application 2, the highlighted rectangles are clickable. Select the desired Appsel Code to implement on the module by simply clicking on a supported Appsel code. Validate your host routine with Nexus in implementing selected Appsel code on module. Once the selected code is set on the module, Nexus will indicate a success with logs. Otherwise, Nexus will indicate a fault related to the Appsel code on the module

The screenshot displays the Nexus Analyzer interface for the Module Behavioral Model. On the left, a large empty box is present. In the center, a list of applications is shown:

- Application 1 : 400GAUI-8 C2M (highlighted)
- Application 2 (highlighted)
- Application 3
- Application 4
- Application 5
- Application 6
- Application 7
- Application 8

On the right, a state machine diagram shows the following states and transitions:

- AppSelCode: 0001** (grey) transitions to **ApplyDPInit** (grey).
- ApplyDPInit** (grey) transitions to **ApplyImmdiate** (grey).
- ApplyImmdiate** (grey) transitions to **ConfigStatus** (grey).
- ApplyDPInit** (grey) also transitions to **ConfigStatus** (grey).

## Network Path State Machine Test

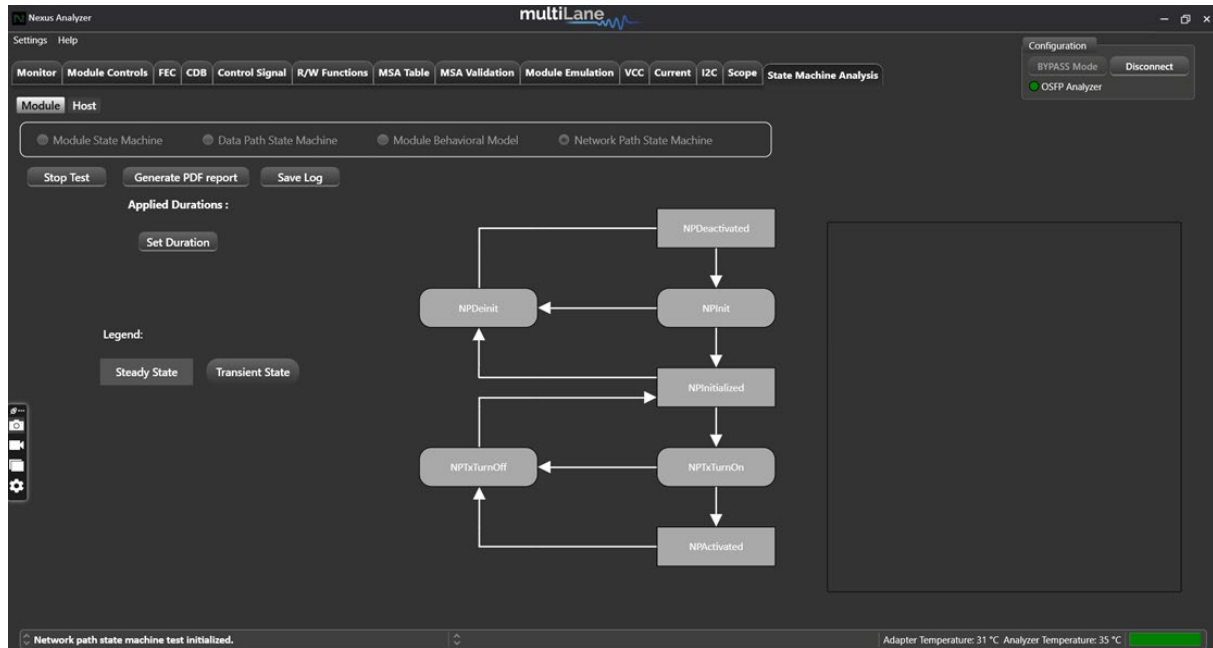

### Host Side

The below tests are all done in target mode. The tests are each initialized by clicking on the desired test, and then pressing “Begin Analysis”:

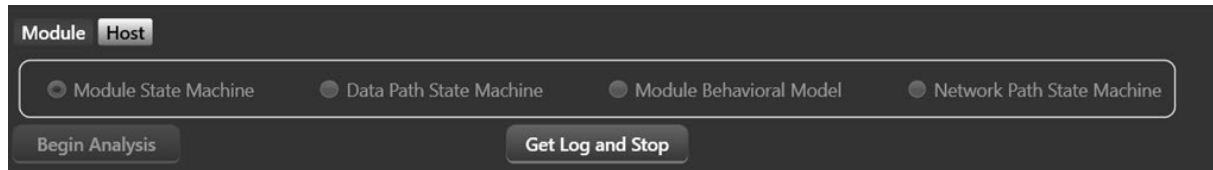

To drive the state machine tests on the host side and validate the host capabilities in implementing state changes on the module, follow the CMIS specifications which the guide refers you to for each test below:

## Module State Machine

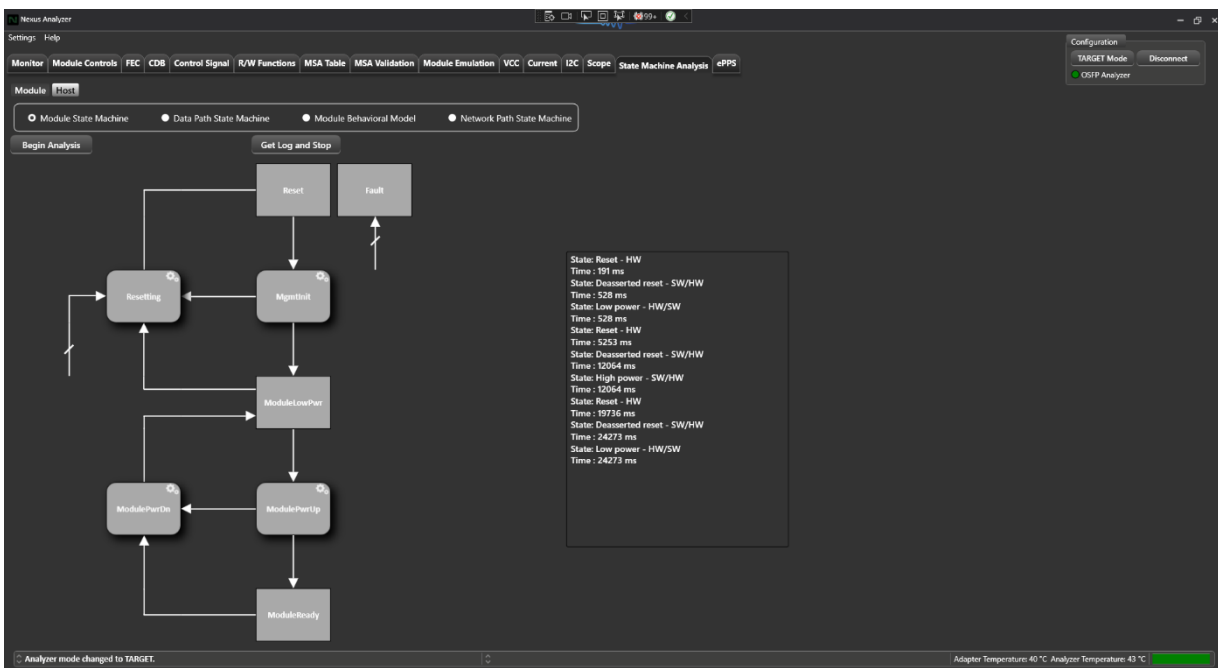

Press on “Begin Analysis”, and manually trigger state transitions from your host which will be reflected here, validating host to module communication.

## Data Path State Machine

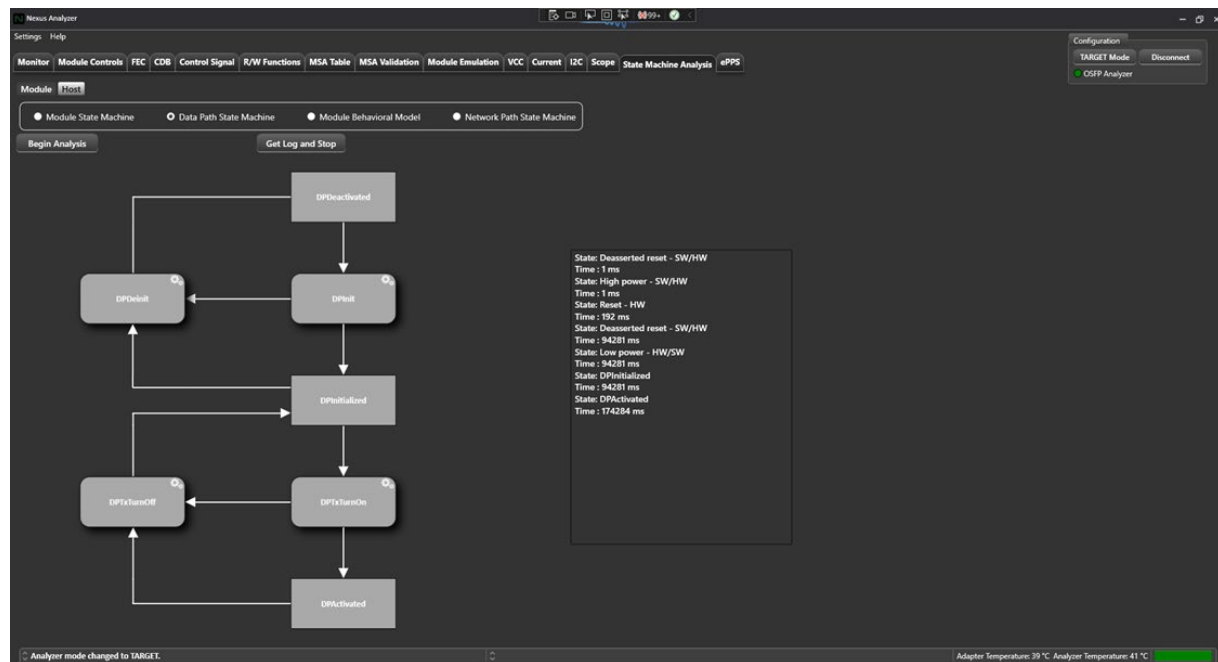

For DPSM host side testing, press on “Begin Analysis”, and then please refer to CMIS 5.2 specifications, section 6.3.3, for more information on how to trigger state transitions from the host side, and check which registers are involved.

**DPDeactivated:**

- Read: page 11h addresses 128-131
- Set module to high power:
  - Write: page 10h (16) address 128 -> 00
  - Write: page 10h (16) address 143 -> FF

**DPInitialized:**

- Read: page 11h addresses 128-131
- Write: page 10h address 132 -> 00
- Write: page 10h address 130 -> 00

**DPActivated:**

- Read: page 11h addresses 128-131 -> 44

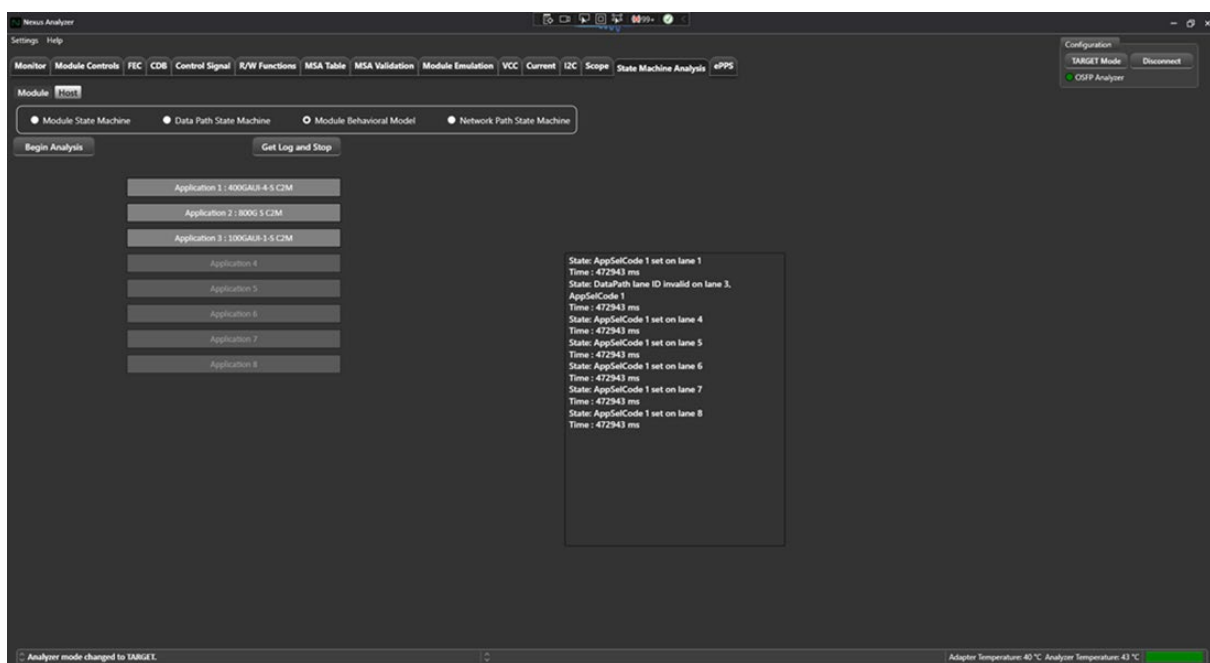
**Module Behavioral Model**

Press on “Begin Analysis”, and change/implement specific apsel codes by writing to the correct registers from the host side. Validate with Nexus.

**400G:**

- write: page 10h (16) address 145 -> 10h (Appsel 0001, lane 1)
- write: page 10h (16) address 146 -> 10h (Appsel 0001, lane 1)
- write: page 10h (16) address 147 -> 10h (Appsel 0001, lane 1)
- write: page 10h (16) address 148 -> 10h (Appsel 0001, lane 1)
- write: page 10h (16) address 149 -> 18h (Appsel 0001, lane 5)
- write: page 10h (16) address 150 -> 18h (Appsel 0001, lane 5)
- write: page 10h (16) address 151 -> 18h (Appsel 0001, lane 5)
- write: page 10h (16) address 152 -> 18h (Appsel 0001, lane 5)
- write: page 10h (16) address 143 -> FF

**800G:**

- write: page 10h (16) address 145 -> 20h (Appsel 0010, lane 1)
- write: page 10h (16) address 146 -> 20h (Appsel 0010, lane 1)
- write: page 10h (16) address 147 -> 20h (Appsel 0010, lane 1)
- write: page 10h (16) address 148 -> 20h (Appsel 0010, lane 1)
- write: page 10h (16) address 149 -> 20h (Appsel 0010, lane 1)
- write: page 10h (16) address 150 -> 20h (Appsel 0010, lane 1)
- write: page 10h (16) address 151 -> 20h (Appsel 0010, lane 1)
- write: page 10h (16) address 152 -> 20h (Appsel 0010, lane 1)
- write: page 10h (16) address 143 -> FF

**100G:**

- write: page 10h (16) address 145 -> 30h (Appsel 0011, lane 1)
- write: page 10h (16) address 146 -> 32h (Appsel 0011, lane 2)
- write: page 10h (16) address 147 -> 34h (Appsel 0011, lane 3)
- write: page 10h (16) address 148 -> 36h (Appsel 0011, lane 4)
- write: page 10h (16) address 149 -> 38h (Appsel 0011, lane 5)
- write: page 10h (16) address 150 -> 3Ah (Appsel 0011, lane 6)
- write: page 10h (16) address 151 -> 3Ch (Appsel 0011, lane 7)
- write: page 10h (16) address 152 -> 3Eh (Appsel 0011, lane 8)
- write: page 10h (16) address 143 -> FF

**Network Path State Machine**

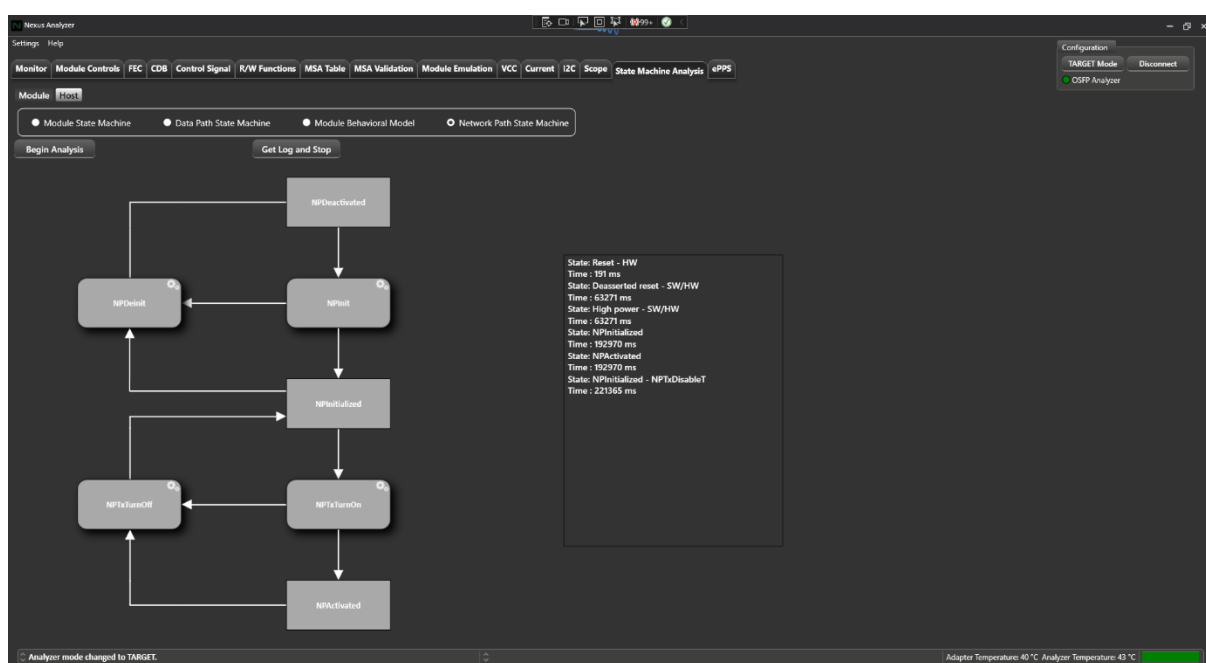

Press on “Begin Analysis”, and then please refer to CMIS 5.2 specifications, section 7.6.7, for more information on how to trigger state transitions from the host side, and check which registers are involved

**NPDeactivated:**

- Read: page 16h addresses 200-203
- Set module to high power
  - Write: page 16h address 128 -> 01
  - Write: page 16h address 160 -> 00
  - Write: page 16h address 176 -> FF

**NPInitialized:**

- Read: page 16h addresses 200-203
- Write: page 10h address 132 -> 00
- Write: page 10h address 130 -> 00

**NPActivated:**

- Read: page 16h addresses 200-203 -> 44

## C-CMIS

Nexus version V0.7.3 includes C-CMIS1.3 support for coherent pluggables.

To access C-CMIS support, refer to “**Configuration**” on the top right side of the GUI, where user has the choice between CMIS5.2 or C-CMIS1.3 specifications support. Select “**C-CMIS1.3**”

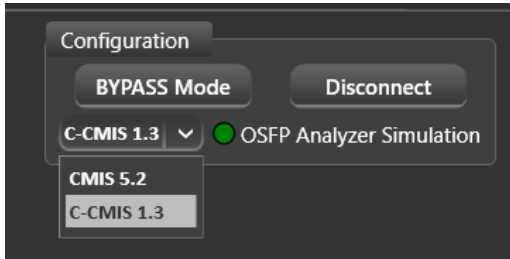

C-CMIS extensions are valid for the following tabs:

- Monitor
- Module Controls
- MSA Table
- MSA Validation

## Monitor

The C-CMIS Monitor operates in initiator mode and includes Media Lane and Host Lane monitoring.

### Media Lane:

Under Media Lane, user has access to “**FEC Performance Monitoring**” and “**Link Performance Monitoring**”

With **FEC Performance Monitoring**, user has access to all 8 lanes. To monitor module parameters, user should check the lanes user wishes to monitor, by checking the box next to each of the lanes in the table.

Name	Lane 1	Lane 2	Lane 3	Lane 4	Lane 5	Lane 6	Lane 7	Lane 8
Number of bits	0	0	0	0	0	0	0	0
Number of bits during sub-interval	0	0	0	0	0	0	0	0
Number of corrected bits	0	0	0	0	0	0	0	0
Minimum number of corrected bits during sub-interval	0	0	0	0	0	0	0	0
Maximum number of corrected bits during sub-interval	0	0	0	0	0	0	0	0
Number of frames	0	0	0	0	0	0	0	0
Number of frames during sub-interval	0	0	0	0	0	0	0	0
Number of frames with uncorrectable errors	0	0	0	0	0	0	0	0
Minimum number of frames with uncorrectable errors during sub-interval	0	0	0	0	0	0	0	0
Maximum number of frames with uncorrectable errors during sub-interval	0	0	0	0	0	0	0	0

With “Link Performance Monitoring”, user can monitor all link parameters respective to each lane, by checking the box next to each of the lanes.

**FEC performance monitoring** | Link performance monitoring

Name	Type	Lane 1	Lane 2	Lane 3	Lane 4	Lane 5	Lane 6	Lane 7	Lane 8
Name: Carrier Frequency Offset - 3 Items									
Carrier Frequency Offset	Average	0	0	0	0	0	0	0	0
Carrier Frequency Offset	Minimum	0	0	0	0	0	0	0	0
Carrier Frequency Offset	Maximum	0	0	0	0	0	0	0	0
Name: Clock Recovery Loop Monitor - 3 Items									
Clock Recovery Loop Monitor	Average	0	0	0	0	0	0	0	0
Clock Recovery Loop Monitor	Minimum	0	0	0	0	0	0	0	0
Clock Recovery Loop Monitor	Maximum	0	0	0	0	0	0	0	0
Name: Differential Group Delay - 3 Items									
Name: DSP Compensated Chromatic Dispersion - 3 Items									
Name: Error Vector Magnitude of the Modem - 3 Items									
Name: ESNR - 3 Items									
Name: High Granularity SOPMD - 3 Items									
Name: Low Granularity SOPMD - 3 Items									
Name: Modulation Error Ratio - 3 Items									
Name: OSNR Estimate - 3 Items									
Name: Polarization Dependent Loss - 3 Items									
Name: Q Factor - 3 Items									
Name: Q Margin - 3 Items									
Name: Rx Input Optical Power - 3 Items									

Adapter Temperature: 54 °C Analyzer Temperature: 39 °C

## Host Lane

With Host Lane, user can monitor host side parameters of each of the lanes on the module by checking the box next to each of the lanes.

**Host Lane**

Name	Lane 1	Lane 2	Lane 3	Lane 4	Lane 5	Lane 6	Lane 7	Lane 8
Number of bits	0	0	0	0	0	0	0	0
Number of bits during sub-interval	0	0	0	0	0	0	0	0
Number of corrected bits	0	0	0	0	0	0	0	0
Minimum number of corrected bits during sub-interval	0	0	0	0	0	0	0	0
Maximum number of corrected bits during sub-interval	0	0	0	0	0	0	0	0
Number of frames	0	0	0	0	0	0	0	0
Number of frames during sub-interval	0	0	0	0	0	0	0	0
Number of frames with uncorrectable errors	0	0	0	0	0	0	0	0
Minimum number of frames with uncorrectable errors during sub-interval	0	0	0	0	0	0	0	0
Maximum number of frames with uncorrectable errors during sub-interval	0	0	0	0	0	0	0	0

Adapter Temperature: 60 °C Analyzer Temperature: 41 °C



## Module Controls

In Module Controls, user has access to Media and Host lanes.

### Media Lanes

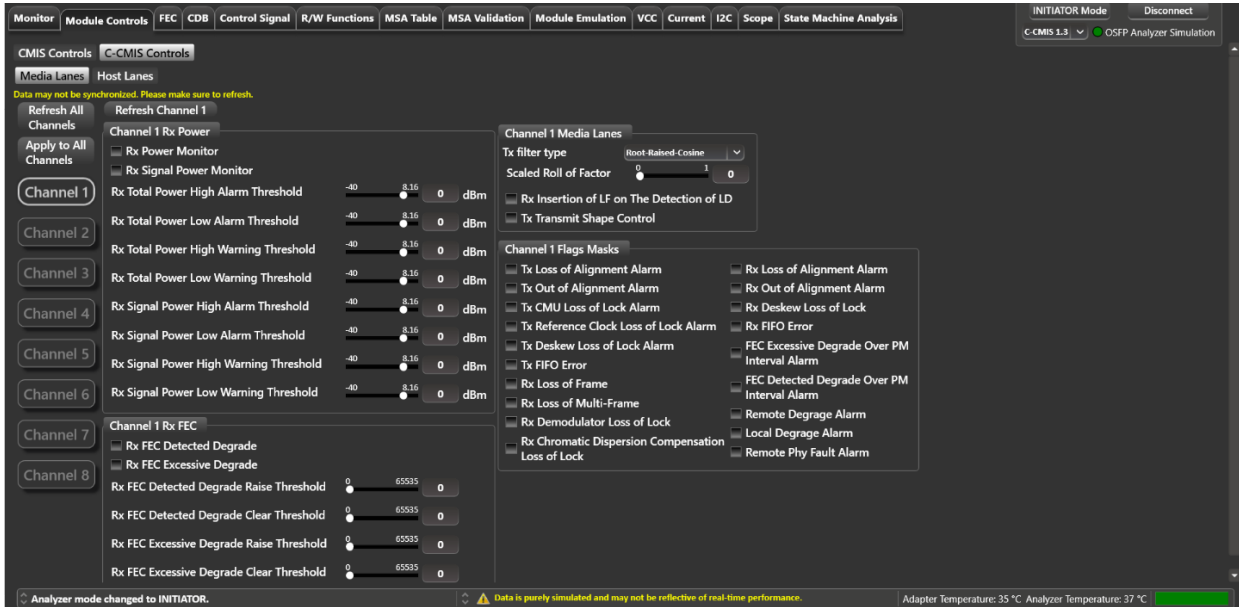

With Media Lanes, user has access to configure:

- Channel Rx Power
- Channel Rx FEC
- Channel Media Lanes
- Channel Flags Masks

User has the option to configure each channel separately, or to apply the same configuration of one channel to all 8 channels, by selecting channels on the left side of the screen, or by selecting “**Apply to All Channels**”.

To set the configuration, if done separately on each channel, press “**Refresh Channel x**”.

To set configuration, if applied to all channels, press “**Refresh All Channels**”

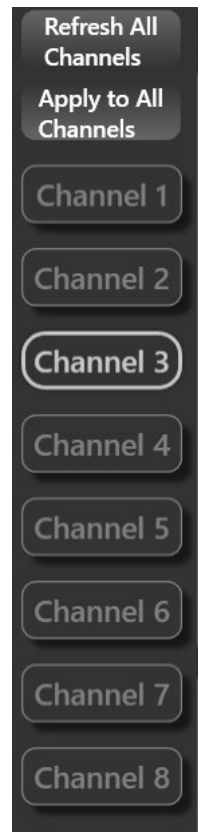

## Host Lanes

Under Host Lanes, user has access to configure:

- Channel Host Lanes Provisioning and Flag Masks
- Channel Host Lanes Configuration

Channel configuration in Media Lanes also applies here.

## MSA Table

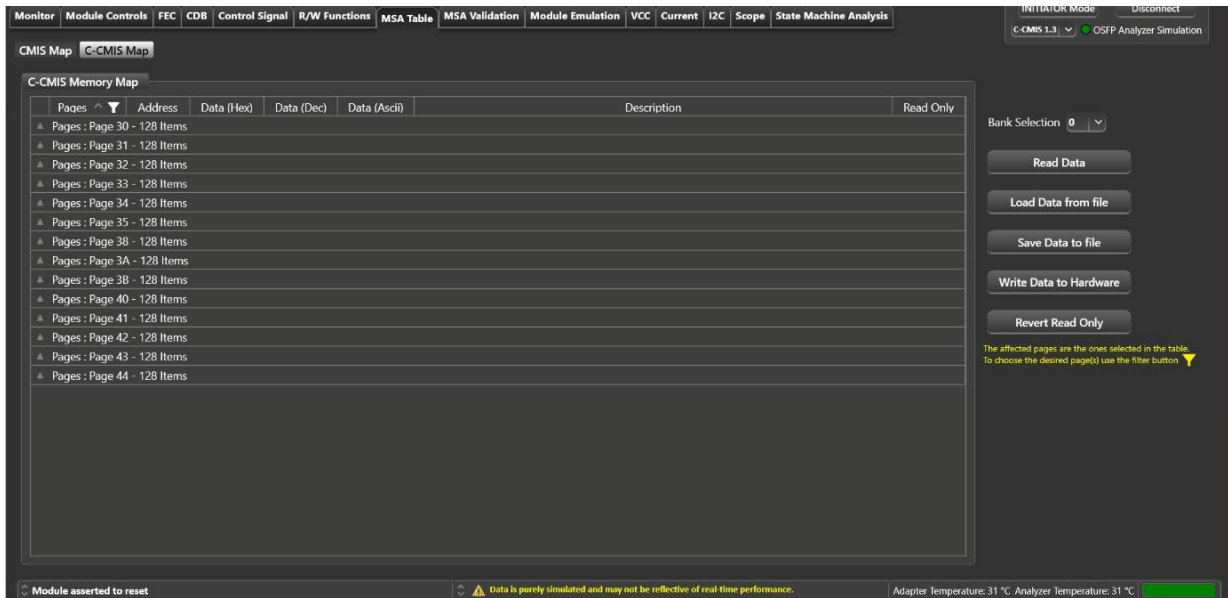

The MSA Table tab works in Initiator mode, giving the user access to their Module Memory. Nexus will display the module memory, with address and description of each register. First, user should configure “**Bank Selection**” on the right side of the screen.

With a “**Read Data**” button, user can read the contents of every register in the module memory. In addition to reading, user can write or change the value of each register, by double clicking on the box of either the “**Data (Hex)**” or “**Data (Dec)**” columns of the desired register. To cement the changes, press on “**Write Data to Hardware**”.



The module memory can be read for all pages at once, or user can also filter the pages and read only a few at once.

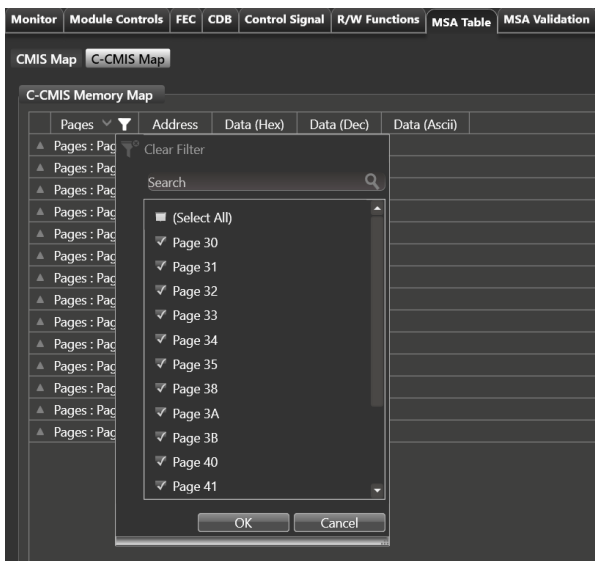

- Operates in initiator mode
- Select bank
- Select page(s) to read
- Read data from device for selected page(s)
- Save data to file
- Load data from file
- Write data to hardware to have the data required in respective addresses
- Read only column: checked boxes refer to read only registers, while unchecked boxes refer to read/write registers, as per MSA. Use these to make R/W registers RO, and RO registers R/W, affecting MSA compliance why?
- Revert read only: revert back to the original type access of all registers as per MSA

## MSA Validation

Start by selection the correct bank.

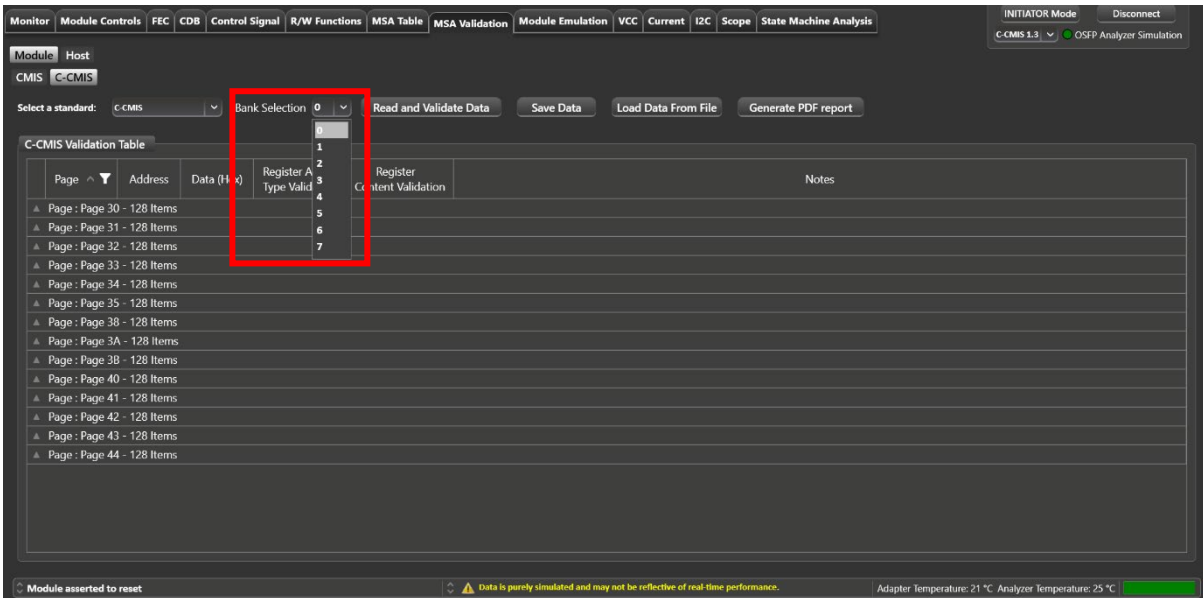

MSA Validation for C-CMIS operates the same as for CMIS. Please refer to section x for guidance.

## Revision History

Revision Number	Date	Description
1.0	6/12/2023	Preliminary
1.1	8/2/2023	Added Module Emulation
1.2	11/1/2023	Added QSFP-DD Support in control signals
1.3	4/9/2024	Instructions for Update 2, v0.7 changes and features.
1.4	5/29/2024	Formatting and Styling
1.5	7/2/2024	C-CMIS update and features

## Software and Firmware Revision History

SW Revision Number	Date	Description	Compatible FW Revision
V0.5.8	26/05/23	<ul style="list-style-type: none"> <li>• Management Interface</li> <li>• FEC</li> <li>• CDB</li> <li>• Control Signals</li> <li>• R/W</li> <li>• MSA Table</li> <li>• MSA Validation</li> <li>• VCC</li> <li>• Current</li> <li>• I2C</li> <li>• Scope Mode</li> <li>• State Machine Test</li> </ul>	V0.3.9 OSFP
V0.5.9.3	18/09/23	Added Module Emulation	V0.3.9 OSFP V0.4.3 QDD
V0.6	14/11/23	<ul style="list-style-type: none"> <li>• Network Path State Machine</li> <li>• Detection of power spikes</li> <li>• Management interface host side</li> <li>• State machine tests host side</li> <li>• MSA Validation host side</li> </ul>	V0.3.9 OSFP V0.4.3 QDD
V0.7	18/06/24	<ul style="list-style-type: none"> <li>• Module Behavioral Model host side</li> <li>• Updated Module Emulation</li> <li>• Updated State Machine Tests</li> <li>• Changes in UI</li> </ul>	V1.6.1 OSFP 1.7.1 QDD
V0.7.3		<ul style="list-style-type: none"> <li>• C-CMIS Update</li> </ul>	V1.6.2 OSFP V 1.7.2 QDD

## Appendix

Accuracy of signals for ML4066-NX-Pro-OSFP REV1.0:

Signal	Notes
VCC	+/- 5 mv accuracy (12 bit sampling resolution)
Current	+/-40 mA accuracy (12 bit sampling resolution)
Operating Temperature	Max 85C
Sampling Resolution	6 bit, 8 bit, 10 bit, 12 bit
Sampling Speed	Min 1 MSPS Max 4.1666 MSPS



### North America

47073 Warm Springs Blvd.,  
Fremont, CA 94539, USA  
+1 510 573 6388

### Worldwide

Houmal Technology Park  
Askarieh Main Road  
Houmal, Lebanon  
+961 81 794 455

### UAE

Building 4WA, Office 420  
Dubai Airport Freezone Authority,  
Dubai, UAE  
+971 4 548 7 547